



OPERATIONS MANUAL

b40 series

b40
b41
b42
b43
b44
b45

4ch digital audio delay
b45



release 3.0

jünger audio

JÜNGER AUDIO - Studioteknik GmbH
Justus-von-Liebig-Str. 7, D - 12489 Berlin, GERMANY
Tel.: +49 30 6777210, Fax.: +49 30 67772146

www.juenger-audio.com

FOREWORD



Thank you for buying and for using the 4-channel Digital Audio Delay B45.

Not only you have acquired the latest generation of digital dynamic range processing, but also a piece of equipment which is unique in its design and specification.

Please read this manual carefully to ensure you have all the information you need to use the 4-channel Digital Audio Delay B45.

The unit was manufactured to the highest industrial standards and went through extensive quality control checks before it was supplied.

If you have any comments or questions about installing, setting-up or using the b45, please do not hesitate to contact us.

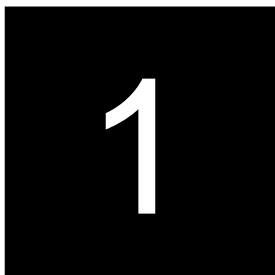

CONTENTS

2.	Function description	2-1
2.1	Basic description	2-1
2.2	Block diagram	2-2
2.3	Remote system	2-3
2.4	Link function / channel configuration	2-4
2.5	Display of delay time	2-4
2.6	Video format	2-4
2.7	Auto tracking	2-5
2.7.1	Auto tracking by video sync	2-5
2.7.2	Auto tracking by TTL control signal	2-6
2.7.3	Auto tracking with offset	2-6
3.	Installation	3-1
3.1	Unpack the unit	3-1
3.2	Power supply	3-1
3.3	Connections	3-1
3.4	Rack mounting	3-1
3.5	Operation safety	3-1
3.6	Synchronization of digital output	3-2
3.7	Remote Control	3-3
3.7.1.	GPI Remote Control	3-3
3.7.2.	Tally Out	3-4
3.7.3.	Serial Remote Control	3-5
4.	Location of parts and controls	4-1
4.1	Front panel	4-1
4.2	Rear panel	4-2
4.3	Switches and jumpers for configuration	4-3
4.4	Selection of Auto Tracking mode	4-4
4.5	Selection of SDI Split Mode	4-4
4.6	Selection of SDI audio group	4-5

5. Setup	5-1
5.0 Description of setup operation	5-1
5.1 Starting and selection of edit menus	5-2
5.2 Main display	5-2
5.3 Adjustment of delay time setup parameters	5-3
5.4 Storage of presets	5-3
5.5 Menu overview	5-4
6. Operation	6-1
6.0 Description of operation	6-1
6.1 Working with presets	6-2
6.2 Recall of presets	6-2
6.3 Adjustment of delay time	6-2
7. Boot display and trouble shooting	7-1
7.1 Boot display	7-1
7.2 Error messages and trouble shooting	7-1
7.3 Initialization the unit	7-2
8. Technical specifications	8-1
9. Warranty and service information	9-1

FUNCTION DESCRIPTION

2

The programmable digital audio delay b45 is a professional studio device for delaying of 4 digital audio channels.

Digital audio delay b45 is working with a new processing algorithm developed by Jünger Audio. It is possible to change the delay time "glitch free" - without changing of pitch, without noises or clicks. Readjustment of audio delay time under live conditions - inaudible and fast done with the digital audio delay b45!

The four channel configuration matches the audio capability of Digital VTR's. B45 can be used as remotable and programmable audio delay in digital video systems.

The unit is programmable, easy to operate and requires only a limited number of settings for fast and efficient audio processing.

- 4 channel programmable digital audio delay
- "glitch free" changing of delay times
- auto tracking function
- up to 1,2 s delay time per channel
- user friendly preset and recall system
- external sync mode, AES/EBU or VIDEO
- RS-422 interface for serial remote
- GPI interface for parallel remote control input, tally output

2.1 BASIC DESCRIPTION

2. FUNCTION DESCRIPTION

2.2 BLOCK DIAGRAM

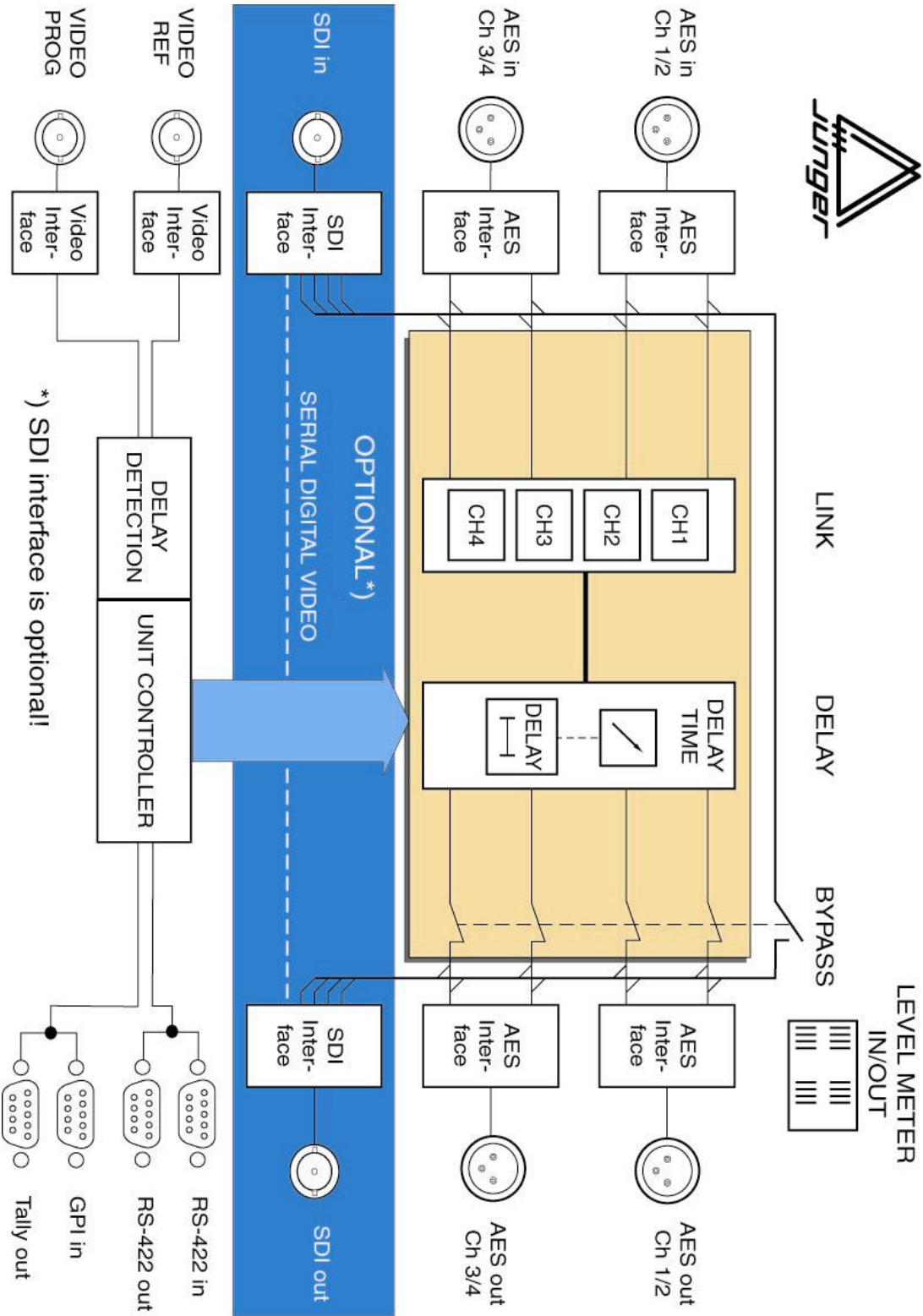

The digital audio delay b45 is fitted with an serial remote interface in RS-422 format.

Every device needs a device address to be registered in a remote system. The address can be selected with the ADDR switch on the rear panel. 16 addresses are selectable (0..F). The preselected address is valid with next power-on reset.

Up to 16 delays b45 can be controlled from one remote panel brc4x.

Device model name and device address are to recognize using the remote protocol of serial remote interface by an automation system or by PC. With it various boxes can be combined in one remote system or remote chain. However a maximum of 16 devices per model can be controlled in one chain.

2.3 REMOTE SYSTEM

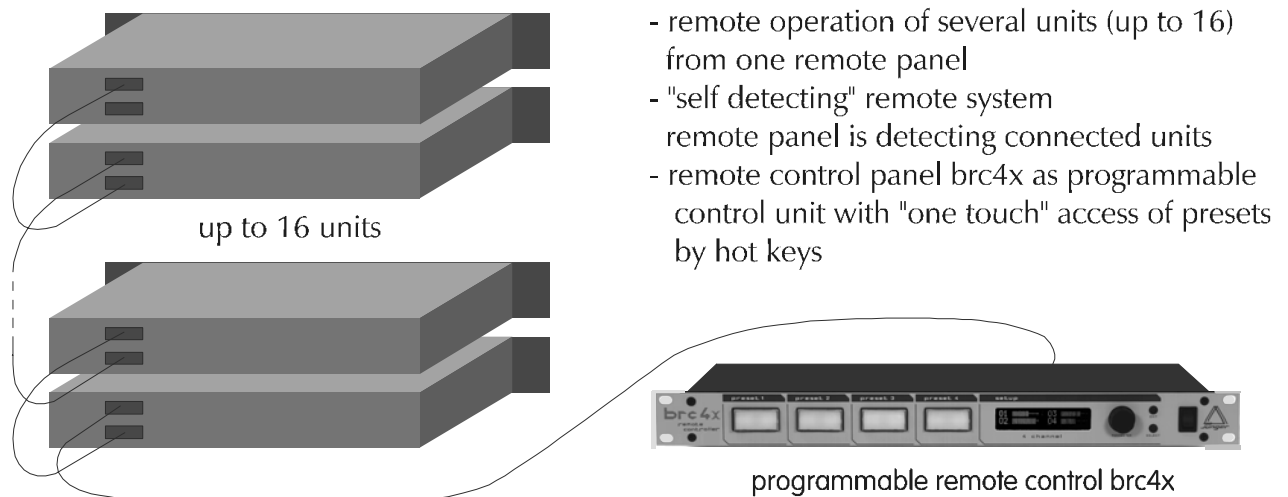

2. FUNCTION DESCRIPTION

2.4 LINK FUNCTION / CHANNEL CONFIGURATION

The LINK function is used for channel configuration regarding delay time adjustment. It enables convenient setting of delay time for a group of audio channels. Following links or channel configuration are possible:

CH1 + CH2 + CH3 + CH4 (all 4 channels linked)

CH1 + CH2 CH3 + CH4 (two linked pairs)

CH1 CH2 CH3 CH4 (all channel independent)

The LINK function is a basic setting and is valid for all presets.

All linked channels are working with the same delay time. Adjustment of delay time is valid for linked channels at the same time.

The display is showing delay time for all four presets (not more for individual channels) if all four channels are linked (P1 ...P4).

2.5 DISPLAY OF DELAY TIME

The adjusted delay time can be displayed in various time scale formats. The time scale format is to select in DELAY menu. The resolution for the adjustment is changing with selection of specific time scale format. For some formats (f.i. frames) adjustment is possible in larger steps only.

Time scale format can be different for different presets. Time scale format will be stored by storing adjustments into the preset.

2.6 VIDEO FORMAT

To get the right delay time (as absolute time value) it is necessary to set the correct video format (PAL/NTSC). The video format is to select in setup menu.

If the unit is synchronized to video reference the selection of video format is done automatically independent of the video format selection in setup menu.

The digital audio delay b45 can be used in Auto Tracking Mode. Auto Tracking means the control of current delay time by specific generated control signal. Together with the „glitch free“ changing of delay time Auto Tracking works without any noises or deterioration in the audio signal.

The control signal for auto tracking can be generated in different ways. Depending on the generation of the control signal it is causing a different maximum length of auto tracking delay time. There are two basic methods to generate the control signal. First one is the comparison of two video signals. The video program signal (VIDEO TRACKING) will be compared with video reference (VIDEO SYNC). Difference in time between both vertical intervals is used as auto tracking delay time. Second way is to use a TTL signal. The length in time of the pulse signal is measured and will be used as current delay time. Selection of auto tracking mode is done by setting jumper J2 on tracking board (see also 4.4).

The digital audio delay b45 can generate the auto tracking control signal by comparison of two video signals. To calculate the auto tracking delay time the algorithm compares the video program signal (VIDEO TRACKING) with video reference (VIDEO SYNC). The difference in time between both vertical intervals is used as auto tracking delay time. The maximum difference and in this way the maximum delay time is one video frame (PAL = 40 ms).

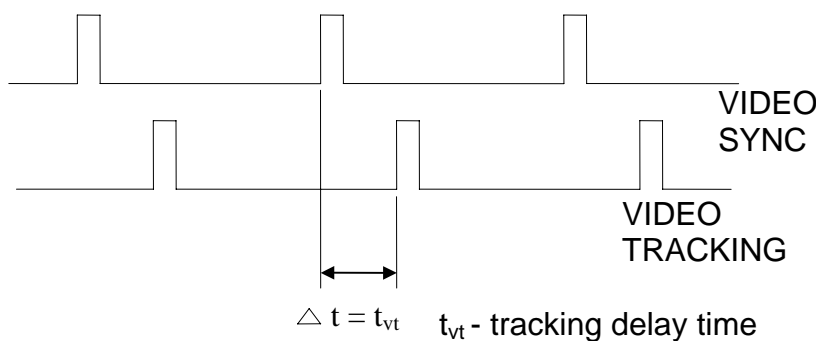

2.7 AUTO TRACKING

2.7.1 AUTO TRACKING BY VIDEO SYNC

2. FUNCTION DESCRIPTION

**2.7.2
AUTO TRACKING
BY TTL CONTROL
SIGNAL**

The digital audio delay b45 can generate the auto tracking control signal by using a TTL control signal. To calculate the auto tracking delay time the detection circuit is measuring the HIGH period of the TTL input signal. The length in time of the HIGH period is used as delay time for auto tracking. The maximum delay time shouldn't be more as the maximum memory capacity of the delay (see technical specifications). Otherwise it produces a memory overflow and an error message will be displayed. Every new positive pulse at TTL input is measured and is overwriting the last calculated value.

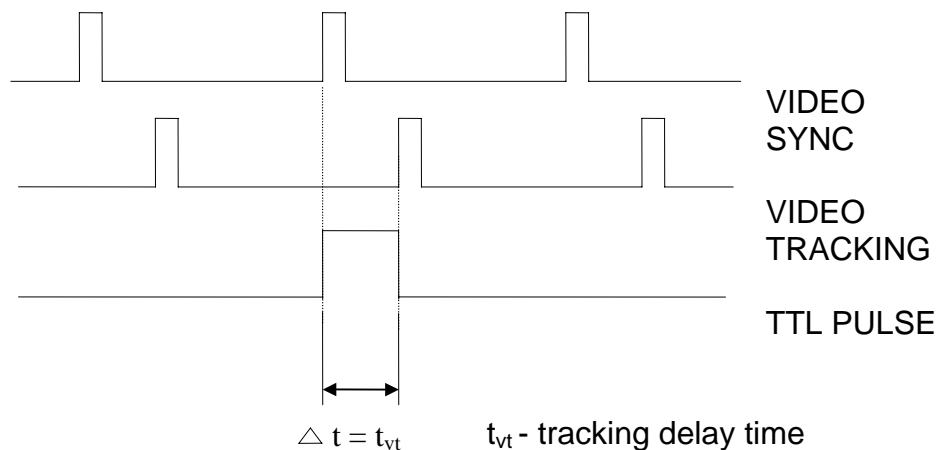

**2.7.3
AUTO TRACKING
WITH OFFSET**

There is the possibility to activate auto tracking even if a fixed delay time is preadjusted. The already adjusted delay time is an offset to the auto tracking delay time. Please note that the overall delay time consisting of delay offset and auto tracking delay time shouldn't be more as the maximum memory capacity of the delay (see technical specifications). Otherwise it produces a memory overflow and an error message will be displayed. The use of the unit is blocked to prevent deteriorated audio signals at digital output.

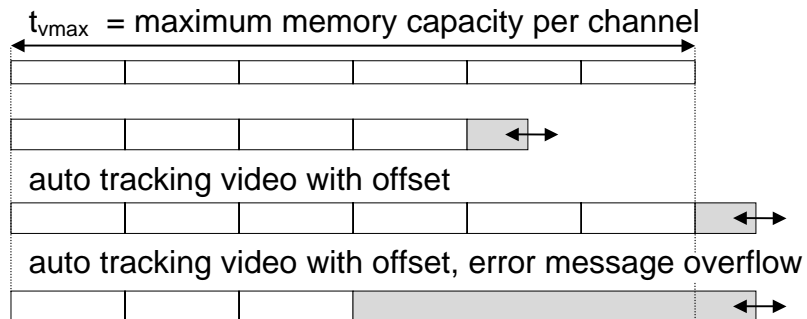

auto tracking TTL with offset, error message overflow
 Note! In auto tracking TTL auto tracking delay time can be longer as one video frame!

INSTALLATION

3

The digital audio delay b45 was carefully packed in the factory and the packaging was designed to protect the equipment from rough handling. Please examine carefully the packaging and its contents for any signs of physical damage, which may have occurred in transit.

3.1 UNPACK THE UNIT

The digital audio delay b45 is a device under the safety category *Schutzklasse 1* in keeping with the VDE 0804 standards and may only be used with power supply installations built according to regulations.

3.2 POWER SUPPLY

Check the voltage details printed at the rear panel are the same as your local mains electricity supply.

The digital audio delay b45 is equipped with standard connectors (see also chapter 3).

3.3 CONNECTIONS

Before connecting the digital audio delay b45 switch the power off at all connected units.

The digital audio delay b45 is made as standard 19" unit (EIA format). It occupies 1 RU (44 mm height) space in a rack.

3.4 RACK MOUNTING

Please allow at least additional 3" depth for the connectors on the rear panel.

When installing the unit in a 19" rack the rear side of the unit needs some support, especially for mounting in flight cases.

3.5 OPERATION SAFETY

The digital audio delay b45 should not be installed near units which produce strong magnetic fields or extreme heat. Do not install the filter processor directly above or below power amplifiers.

If, during operation, the sound is interrupted or displays no longer illuminate, or if abnormal odor or smoke is detected immediately disconnect the power cord plug and contact your dealer or Jünger Audio.

3.6 SYNCHRONIZATION OF DIGITAL OUTPUT

The digital audio delay b45 has a digital signal output only. To the problem-free combination of following digital devices, the digital signal processing can be locked to an external clock reference. The selection of the corresponding input is made in the SYNC MODE menu. If the chosen sync input is connected with the sync signal, this signal is used for synchronization automatically. The digital output signal can be clocked with the following clock frequencies:

CH 1/2 locks with the clock frequency of the input signal at digital input CH 1/2 (AES/EBU, 48 kHz)

EXT SYNC locks with the clock frequency at the external sync input (AES/EBU, 48 kHz)

VIDEO locks with the clock at the Video sync input (internal 48 kHz)

SDI VIDEO locks with the clock at the SDI input (internal 48 kHz)

Both digital outputs CH 1/2 and CH 3/4 are locked with same clock frequency.

Note: SDI sync is available only if SDI input is active!

**3.7
REMOTE
CONTROL**

**3.7.1
GPI REMOTE
CONTROL
(PARALLEL
REMOTE)**

The Digital audio delay b45 can be remote-controlled by means of parallel GPI contacts.

use: remote-controlled changeover of presets

connector: D-SUB 9pin, female

Pin assignments

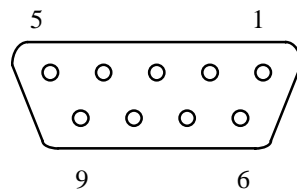

Pin	Signal name	Logic	I/O	Functions
1	PRESET1	L	I	call preset1
2	PRESET2	L	I	call preset2
3	PRESET3	L	I	call preset3
4	PRESET4	L	I	call preset4
5	not used			
6	BYPASS	L	I	bypass on
7	not used			
8	not used			
9	GROUND			Ground

Electrical specification:

GPI input On: connection to ground
 Off: open

signal input level L: 1,5V or less, min. 50ms
 level H: 3,5V or more

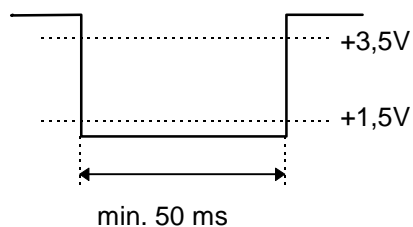

3. INSTALLATION

3.7.2 TALLY OUT

The Digital audio delay b45 can signal specific device statuses via parallel Tally lines.

use: Control of the remote-controlled changeover of presets

connector: D-SUB 9pin, male

Pin assignments

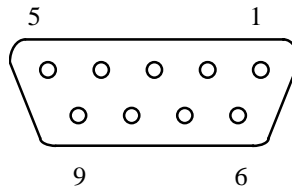

Pin	Signal name	Logic	I/O	Functions
1	PRESET1	H	O	preset1 recalled
2	PRESET2	H	O	preset2 recalled
3	PRESET3	H	O	preset3 recalled
4	PRESET4	H	O	preset4 recalled
5	LIMITER	H	O	limiter on
6	BYPASS	H	O	bypass on
7	SYNC ch1/2	H	O	input 1/2 locked
8	SYNC ch3/4	H	O	input 3/4 locked
9	GND			Ground

Electrical specification:

signal input

level L: 1,5V or less
level H: 3,5V or more

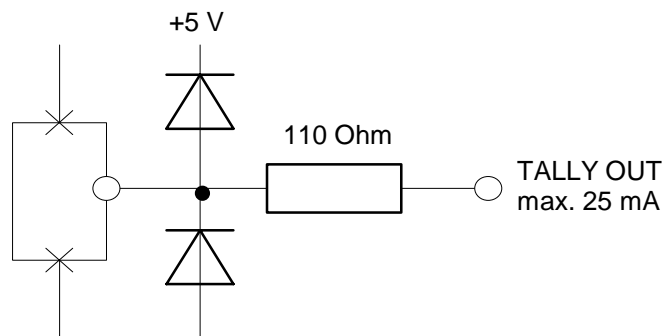

The Digital audio delay b45 can be remote-controlled by means of serial remote RS-422.

use: remote-controlled changeover of presets

protocol: available on request

connector: D-SUB 9pin, input - male
output - female

Pin assignments

The cable is wired 1:1 completely, the shield of the cable must be connected on both ends!

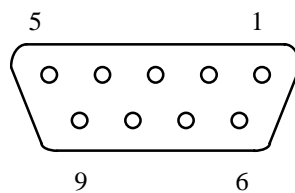

REMOTE IN

Pin	Signal name	Functions
1	DSR + out	Data set ready
2	DSR - out	
3	SENSE in	Interrogation Remote
4	RXD + out	Receive data
5	RXD - out	
6	DTR + in	Data terminal ready
7	DTR - in	
8	TXD + in	Transmit data
9	TXD - in	

REMOTE OUT

Pin	Signal name	Functions
1	DSR + in	Data set ready
2	DSR - in	
3	GND	GND
4	RXD + in	Receive data
5	RXD - in	
6	DTR + out	Data terminal ready
7	DTR - out	
8	TXD + out	Transmit data
9	TXD - out	

Electrical specification:

signal in/outputs

TTL-level

**3.7.3
SERIAL REMOTE
CONTROL
(RS-422)**

LOCATION OF PARTS AND CONTROLS



All control elements give direct access.
In menu modes the LCD-panel shows specific functions.

4.1. FRONT PANEL

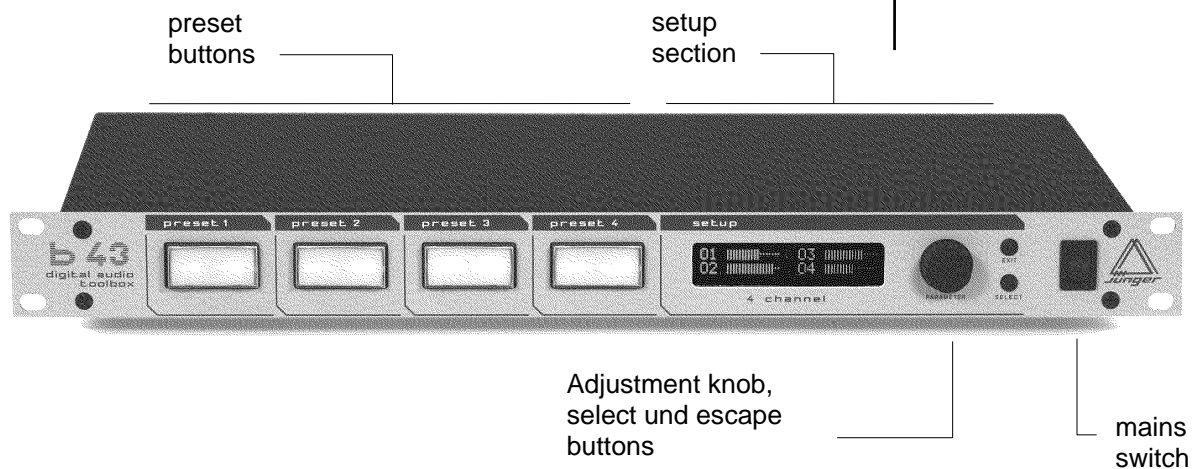

fig1: front panel b45

PRESET 1...4	selection of presets 1...4
CONTROL	selection (push) and adjustment (turn) of parameters
SELECT	selection of menus (for adjustment of parameters)
EXIT	exit of adjustment menus and return to level display

CONTROL ELEMENTS

4. LOCATION OF PARTS AND CONTROLS

4.2. REAR PANEL

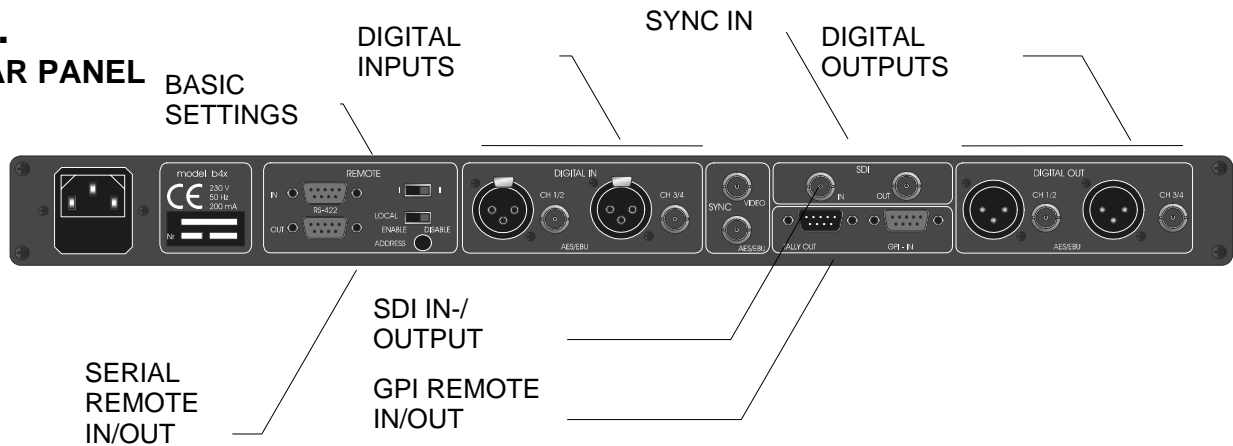

fig. 2: rear panel b42

POWER INPUT

IEC mains input connector 230 V, 50 Hz (UK: 240 V, 50 Hz; JAPAN: 100 V, 60 Hz; USA: 127 V, 60 Hz) with integrated fuse

REMOTE

serial remote interface RS-422

connector: 9pin SUB-D, input - male, output - female

GPI

paralle remote interface

TALLY-out TTL-level

connector: 9pin SUB-D, male

GPI-in TTL-level

connector: 9pin SUB-D, female

SYNC

AES/EBU input for ext. sync signal (AES 3 format, 75 Ohm, unbal)

connector: BNC socket

VIDEO input for video sync signal (blackburst, 75 Ohm, unbal)

connector: BNC socket

SDI IN / OUT (only for SDI-Version!)

Input/output for serial digital video (ITU-R BT.601, SMPTE 272M-A) with embedded audio

Format: 270 Mb/s, 525/625 line rate, 75 Ohm,

connector: BNC socket

DIGITAL IN

input for AES/EBU standard format

connector: XLR female panel jack

1- ground, 2-3 signal, balanced

connector: BNC socket 75 Ohm, unbalanced

DIGITAL OUT

output for AES/EBU standard format

connector: XLR male panel jack

1- ground, 2-3 signal, balanced, 4 Vpp

connector: BNC socket 75 Ohm, unbalanced, 0.5V pp

**4.3
SWITCHES AND
JUMPERS FOR
CONFIGURATION**

Some basic settings are to select by switches on the rear panel or by switches and jumpers at the internal circuit boards of the unit. These settings can occur general changes for operation and should made by qualified engineering staff only.

Rear panel

Following switches in the REMOTE- field at rear panel are used for configuration of the unit.

SDI Bypass switches SDI bypass on/off (see also 3.10)
(only for SDI version!)

LOCAL Setting of FRONT PANEL operation mode

ENABLE Unit can be controlled by front panel **and** by serial remote interface.

DISABLE Unit can be controlled only by using serial remote interface. Front panel is locked.
Note: DISABLE is only activated if serial remote control is connected!

ADDR Selection of the device address for serial remote, 16 device addresses selectable
Note: Within a line of remote controlled units every device needs a different address! The selected address is valid after next power-on reset of the unit.

Internal

To set any internal jumper or switches it is necessary to open the unit.

PLEASE DO NOT MAKE ANY ALTERATIONS WITH THE MAINS STILL CONNECTED TO THE UNIT!

Loosen the screws on the top cover and remove. Then you can see all jumper and switches as shown in the drawing below. After setting of jumper or switches reassemble the unit in opposite order.

4. LOCATION OF PARTS AND CONTROLS

**4.4
SELECTION OF
AUTO TRACKING
MODE**

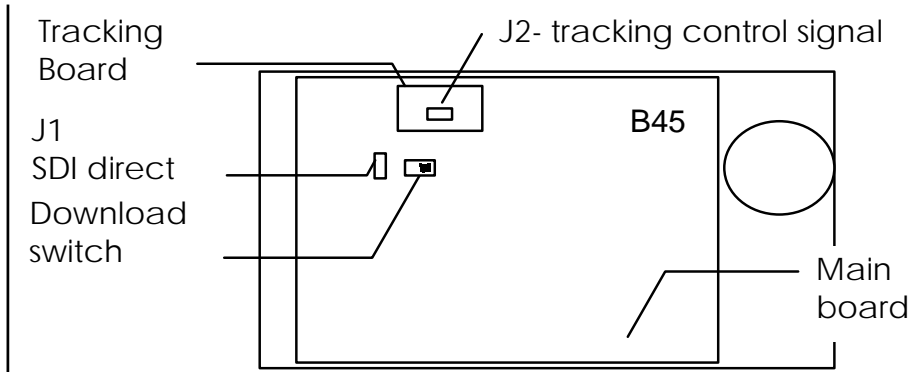

Use jumper J2 on the tracking board for selection of tracking mode (tracking control signal input) (see also 2.).

Auto Tracking

with Video

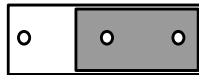

J2

with TTL

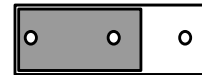

J2

All following settings are related to the SDI interface. The SDI interface can be fitted only after removing the tracking module. That means if the box is equipped with SDI interface no tracking functions are available anymore!

**4.5
SELECTION OF
SDI SPLIT MODE**

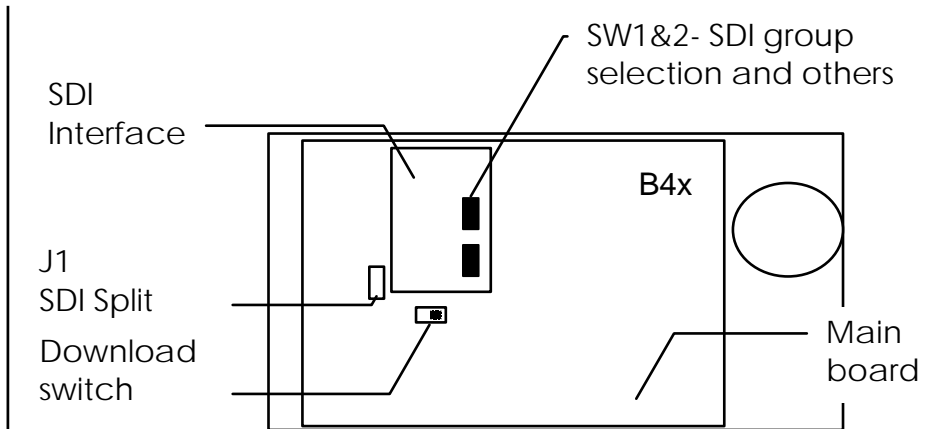

Units with SDI interface can be used in SDI split mode:

Audio in path

SDI input > AES output

Audio out path

SDI output > dsp processing > AES output

(see also 2.5)

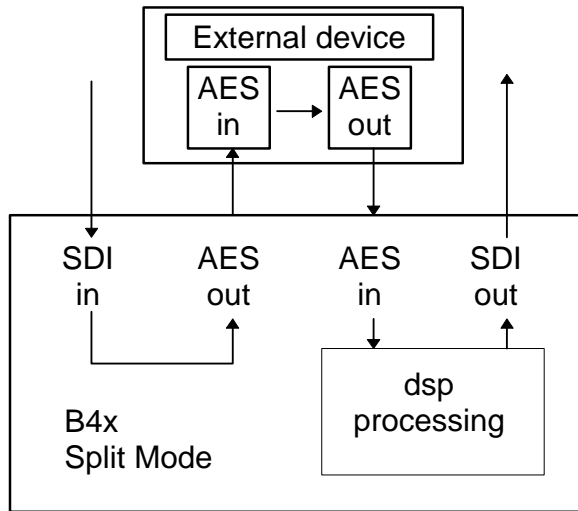

The selection of split mode (SDI DIRECT) is made by setting jumper J1 on main board of the unit.

The 4-channel processors of b40 series fitted with SDI-interface are compatible with the standard SMPTE 272M-AB. They support 48 kHz synchronous audio sampling with 20 bit word length.

The standard allows up to four groups each of four mono audio channels. (Usually used by most of D-VTR's and other equipment is Group 1 with 48 kHz synchronous sampling.)

Group selection and other settings are to configure with switches on the SDI board as described following:

Settings on SDI interface board:

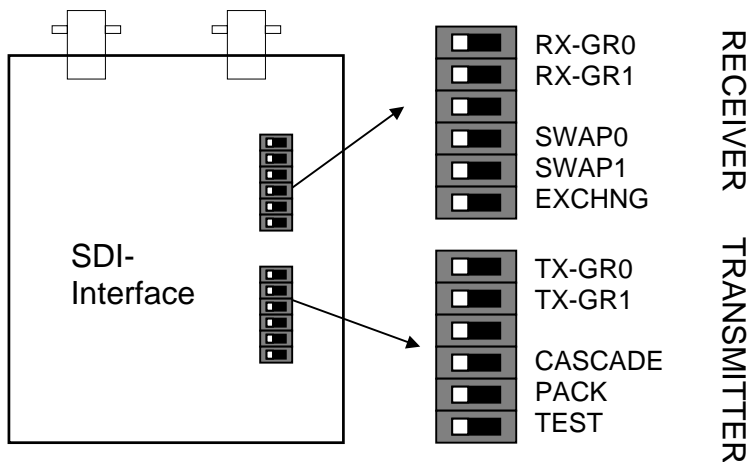

4.6 CONFIGURATION OF SDI INTERFACE

4. LOCATION OF PARTS AND CONTROLS

Group selection for receiver: valid anytime
for transmitter: valid only in PACK or in CASCADE mode

	GR0	GR1
group 1	-	-
group 2	x	-
group 3	-	x
group 4	x	x

x – switch is set to ON

Channel swap for receiver:
SWAP0 swaps channel 1&2
SWAP1 swaps channel 3&4
EXCHNG swaps pairs 1/2&3/4

PACK

- generates a new audio frame structure (is deleting all former existing embedded audio!)
- is embedding selected TX group as first audio group within SDI stream
- necessary if no audio was embedded before

CASCADE

- generates a new audio group as selected (TX group) within existing frame structure (is overwriting all data of this group if it was already existing)
- necessary if a new group should be embedded and if audio in other groups was embedded previously
- is matching ideally the structure which was generated by PACK mode (It is recommended to use PACK mode for generating audio structure and embedding the first group before using CASCADE to embed further audio groups!)

Please note: As long as PACK and CASCADE are not set the embedder is inserting in the group which is determined by RX group selection. The embedder is replacing the existing audio if it was embedded previously.

If group 1 is selected and no audio structure is existing at the input the embedder is switching to PACK mode for group 1 automatically!

If group 2,3 or 4 is selected and no audio structure is existing for this group the embedder is not inserting audio data (use PACK or CASCADE!).

Test not in use

SETUP





The setup or the programming of the digital audio delay b45 is made by adjustment of various parameters.

The description is made related to the functions in the EDIT mode.

- 5.1 starting and selection of EDIT menus
- 5.2 main display
- 5.3 adjustments of delay time and setup parameters
- 5.4 storage of presets
- 5.5 parameter overview

5.0 DESCRIPTION OF SETUP OPERATIONS

Following syntax is used:

SYMBOL	ACTIVITY
<p>describes how to use button or rotary knob</p>  <p>push</p>  <p>turn</p>  <p>push + turn</p>	<p>describes action or function of button or rotary knob</p>

5. SETUP

5.1 STARTING AND SELECTION OF EDIT MENUS

For opening and selection of EDIT menus.



SELECT

for opening and selection of EDIT menus

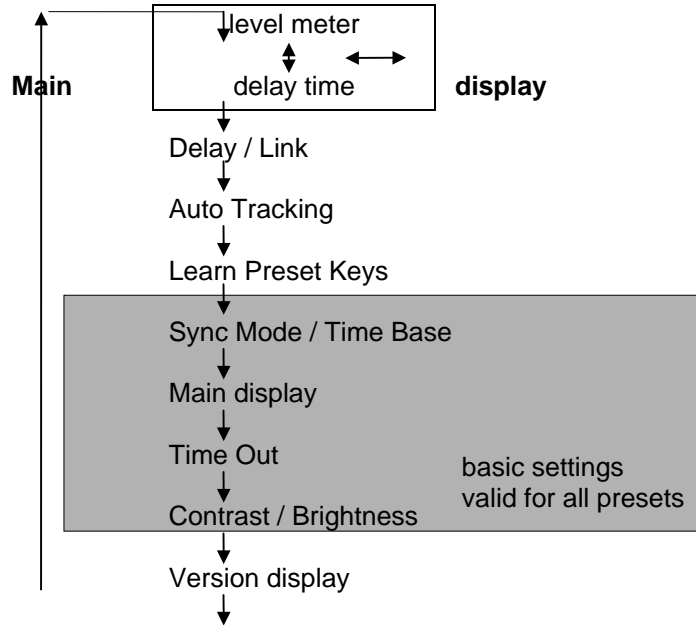

EXIT

Reset to main display, basic settings
are stored automatically

individual preset adjustments are only to store by doing „learn preset keys“!

5.2 MAIN DISPLAY

The main display shows either the signal level or the delay time. The display mode is to select in MAIN DISPLAY menu. The not displayed item is to call by pushing SELECT button anytime.

The display of delay time is different dependent on selected link mode.

4 channels independent (4 different delay times possible):

C1: ____ C2: ____

C3: ____ C4: ____

two pairs linked:

LINK C1 + C2: ____ C = channel

LINK C3 + C4: ____ P = preset

4 channels linked (one delay time for all four channels):

P1: ____ P2: ____



P3: ____ P4: ____

Note: If all four channels are linked the display shows one delay time for each preset! Delay times can be changed by pushing and turning CONTROL knob. Values are stored automatically!

Signal level display can show input level for all four channels. Audio level is displayed as bargraph. This display is not scaled. Two segments are appr. 2dB of audio level. The level display gives information about the existence and the size of the audio signals.





After selection of delay time display or setup menu by pushing SELECT button one can adjust displayed time values or parameter.

- 
CONTROL
selection of parameter, selected parameter blinks on display
- 
CONTROL
adjustment of selected parameter (see also parameter overview)

Each time SELECT button is pushed it opens the next setup menu. After finishing of settings EXIT button switches back to main display. All basic settings are stored automatically.

Note: After finishing of **adjustment of delay times** EXIT button switches back to main display **without storage** of values. If you want to store adjusted delay times as preset you have to store them by „learn preset key“-function (see 6.4).

Link mode (delay link between channels), delay scaling and delay time value are storable into 4 individual presets.

- 
SELECT
for selection of teach-in preset menu, „learn preset key“ function
- 
PRESET 1...4
storage of current adjustments into preset 1...4

Note: If all four channels are linked display shows one delay time for each preset! Delay time can be changed by pushing and turning CONTROL knob. Delay time scaling and values are stored like a basic setup item automatically without to use teach in preset function! In four channel link mode you don't need to use „learn preset key“ function.

5.3 ADJUSTMENT OF DELAY TIME AND SETUP PARAMETERS

5.4 STORAGE OF PRESETS

5. SETUP

5.5 MENU OVERVIEW

tab.1:
menu parameter b45

MENÜ	SCALE	STEPS	VALUE
DELAY TIMES			Ch 1...4 or Preset 1..4
LEVEL METER			Ch 1...4
DELAY	SAMPLES S	1	0...16383
	MILLISEC: MS	1	0...340
	FRAMES FR	0.1	0...8,5
	FIELDS FD	1	0...17
	METER M	1	0...100
LINK			1+2+3+4; 1+2 3+4; 1 2 3 4
AUTO *)			ON/OFF for Ch 1...4
SYNC MODE			CH1+2, EXTERN, VIDEO
TIME BASE **)			PAL, NTSC
MAIN DISPLAY			DELAY, METER
TIME OUT	SECONDS	1	0...20
CONTRAST		1	0...7
BRIGHTNESS		1	0...7
VERSION			D:xx, max. delay, C:xx

DELAY TIMES	display and adjustment of delay times for ch1..4 or preset 1...4
LEVEL METER	display of input level ch 1..4
DELAY	time scale format of delay time values
LINK	all linked channels are using same delay time
AUTO *)	selection of auto tracking mode ch 1...4
SYNC MODE	selection of sync signal input
TIME BASE **)	selection of video format
MAIN DISPLAY	selection of basic display mode (level/time)
TIME OUT	adjustment of maximum processing time for glitch-free changing of delay time
CONTRAST	display adjustment
BRIGHTNESS	display adjustment
VERSION	display of software version (dsp = D:xx, controller = C:xx) and maximum delay time per channel (in ms)

*) only available if video sync mode is selected

***) only available if video sync mode is not selected, if sync on video automatic setting

OPERATION



The use of the digital audio delay b45 is very easy. Only a few settings are necessary for working with the unit.

The description is made related to the functions in the EDIT mode.

- 6.1 working with presets
- 6.2 recall of presets
- 6.3 adjustment of delay time

6.0 DESCRIPTION OF OPERATION

Following syntax is used:

SYMBOL

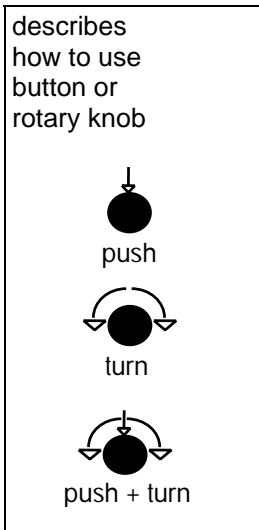

ACTIVITY

describes action or function of button or rotary knob

6. OPERATION

6.1 WORKING WITH PRESETS

The digital audio delay b45 is a programmable audio delay.

It is to control by recalling of presets. It has four preset buttons with which the appropriate preset is called on in each case. In a preset, all parameters which can be adjusted at the device are contained. Therefore, one will normally define four operating states, to store them as presets. The desired device function can then be activated fast and simply by calling the corresponding preset (at the device or by external control). The parameters displayed in the LCD display can be changed with the PARAMETER knob.

6.2 RECALL OF PRESETS



PRESET 1...4

recall of programmed adjustments
of preset 1...4

6.3 ADJUSTMENT OF DELAY TIME

The delay time values in the LCD display can be changed with the PARAMETER button.



CONTROL

selection of parameter, selected parameter
blinks on display



CONTROL

adjustment of selected parameter
(see also parameter overview)

Note: After finishing of adjustment of delay time EXIT button switches back to main display without permanent storage of changed values. If you want to store adjusted delay time into preset you have to store them by „learn preset key“-mode (see 5.4).

BOOT DISPLAY AND TROUBLE SHOOTING

7

display	meaning / explanation
AUDIO DELAY	display of model
B45	display of type
64k	display of RAM capacity
ADR. xx	address of device for serial remote control
C: x.x	display of loaded controller software version
D: x.x	display of loaded dsp software version

7.1 BOOT DISPLAY

display	error / message	remedies
NO SYNC	no sync at digital input!	<ul style="list-style-type: none"> ■ connect the digital input or sync input (selectable in SYNC menu) with valid input signal ➤ CH 1/2: sync on DIGITAL IN CH 1/2 ➤ EXT: sync on SYNC AES/EBU ➤ VIDEO: sync with video ref.
LOCAL DISABLED! NO REMOTE DETECTED	Front panel locked and no remote connected!	<ul style="list-style-type: none"> ■ set switch LOCAL to ENABLE or ■ connect unit with remote panel or serial remote

7.2 ERROR MESSAGES AND TROUBLE SHOOTING

**7.3
INITIALIZATION
THE UNIT**

Should have remained the device no more operable and/or in the program execution stand, recommends itself an initialization the device.

During initialization, all storage areas important for the program and registers are loaded with the factory setup and the program is restarted.

Any button is to be held pressed in order to initialize the device during switch-on of the device until the program started. To the start of the program and at the completion of the displays (how described in 7.1), the device is ready for operation with the factory setup.

After an initialization of the device, all user presets and adjustments are erased and/or overwritten by the factory setup!

TECHNICAL SPECIFICATIONS

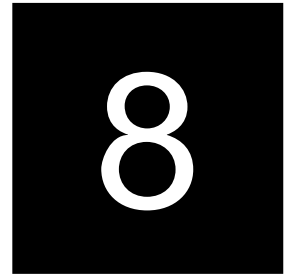

sample rate : 48 kHz
 audio data format : 24-bit (AES/EBU, SDI)
 delay time : 0...340ms per channel (for 64kB RAM)
 0...1,3s per channel (for 256kB RAM)

DIGITAL IN/OUT

AES/EBU

connector : XLR, 110 Ohm, balanced
 BNC, 75 Ohm, coaxial
 input format : AES professional, AES consumer
 output format : same as input format

SYNC IN

AES/EBU

connector : BNC, 75 Ohm, coaxial
 level : 0,5 ... 5 Vpp
 input format : AES professional, AES consumer

VIDEO

connector : BNC, 75 Ohm, coaxial
 level : 0...1 Vpp
 input format : Blackburst or PAL/NTSC composite video

TRACKING

VIDEO

connector : BNC, 75 Ohm, coaxial
 level : 0...1 Vpp
 input format : Blackburst or PAL/NTSC composite video

TTL

connector : BNC, 75 Ohm, coaxial
 level : TTL; 0 ... 5 Vpp
 input format : t_{high} = tracking delay time

digital signal
processing

digital
in- / outputs

analog and digital
inputs for
synchronisation

analog and digital
inputs for tracking
control signal

8. TECHNICAL SPECIFICATIONS

remote control

REMOTE

serial remote interface RS-422 in/out

level : TTL

connector : 9 pin SUB-D male/female

parallel remote GPI

level : TTL

connector : 9 pin SUB-D female

Tally Out

level : TTL, max 25mA

connector : 9 pin SUB-D male

SDI (if fitted with)

SDI IN/OUT

(only for SDI version)

connector : BNC, 75 Ohm, coaxial

data rate : 270 Mb/s, 525/625 Line rate

format : serial digital component video 4:2:2
with embedded audio
(ITU-R BT.601, SMPTE 272M-A)

general

power consumption : appr. 15 VA

dimensions : 19", 1 RU, 250 mm depth

weight : appr. 5 kg

options : programmable remote control brc4x

WARRANTY AND SERVICE INFORMATION

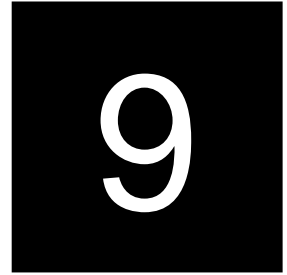

JÜNGER AUDIO grants a two-year warranty on the

4-channel digital audio delay b45

If the unit has to be serviced, please send it, ideally in the original box, to:

JÜNGER AUDIO - Studiotechnik GmbH

Justus-von-Liebig-Str. 7

D - 12489 Berlin
GERMANY

Tel.: (*49) -30-677721-0
Fax.: (*49) -30-677721-46



KONFORMITÄTSERKLÄRUNG

DECLARATION OF CONFORMITY

Geräteart : **4ch digital audio delay**
Type of equipment : **4ch digital audio delay**

Produkt / Product : **b45**

Das bezeichnete Produkt stimmt mit den Vorschriften folgender EU-Richtlinie(n) überein:
The aforementioned product complies with the following European Council Directive(s):

89/336/EWG (geändert durch 91/263/EWG und 92/31/EWG)
(changed by 91/263/EEC and 92/31/EEC)
Richtlinie der Rates zur Angleichung der Rechtsvorschriften der Mitgliedsstaaten über die elektromagnetische Verträglichkeit
Council Directive on the approximation of the laws of the Member States relating to electromagnetic compatibility

73/23/EWG (geändert durch 93/68/EWG)
(changed by 93/68/EEC)
Richtlinie des Rates vom 19. Februar 1973 betreffend elektrische Betriebsmittel zur Verwendung innerhalb bestimmter Spannungsgrenzen
Council Directive of February 19th 1973 concerning electrical equipment for operation within certain voltage limits

Zur vollständigen Einhaltung dieser Richtlinie(n) wurden folgende Normen herangezogen:
To fully comply with this(these) Directive(s), the following standards have been used:

EN 55022 : 1987
EN 50082-1 : 1993
EN 60065 : 2002

Dieser Erklärung liegen zugrunde : Prüfbericht(e) des EMV-Prüflabors
Interne Vorschriften zur Sicherheits-Prüfung
This certification is based on : Test report(s) generated by EMC-test laboratory
Internal regulations for safety check

MEB Messelektronik Berlin : Kalibrier- und Prüflabor
accredited EMC laboratory

Aussteller / Holder of certificate : Jünger Audio Studioteknik GmbH
Justus-von-Liebig-Strasse 7
D - 12489 Berlin

Berlin, 18.03.2003
(Ort/Place) (Datum/Date) (Herbert Jünger, Geschäftsführer/Managing Director)



professional audio products

digital dynamics processors d01, d02
accent1, accent2

digital filter processor e07

surround products multichannel digital
dynamics processor ORION
5.1 level controller 206

digital voice processing voice and monitor processor v01
digital voice processor v02
dual channel voice processor v03
digital voice processor v05

digital desktop mixer mix4

transmission signal processing digital transmission processor d07
digital transmission limiter mpx01

4channel processors b40series digital audio toolbox b40
digital audio limiter b41
digital dynamics processor b42
digital audio toolbox b43
SDI audio converter / router b44
digital audio delay b45

digital audio
modular processing system C8000

SDI interface modules SDI20

jünger audio

JÜNGER AUDIO - Studioteknik GmbH
Justus-von-Liebig-Str. 7, D - 12489 Berlin, GERMANY
Tel.: +49 30 6777210, Fax.: +49 30 67772146

www.junger-audio.com