

b41

4 ch digital audio limiter

Manual

release 2.3.0 / 2007-09-04

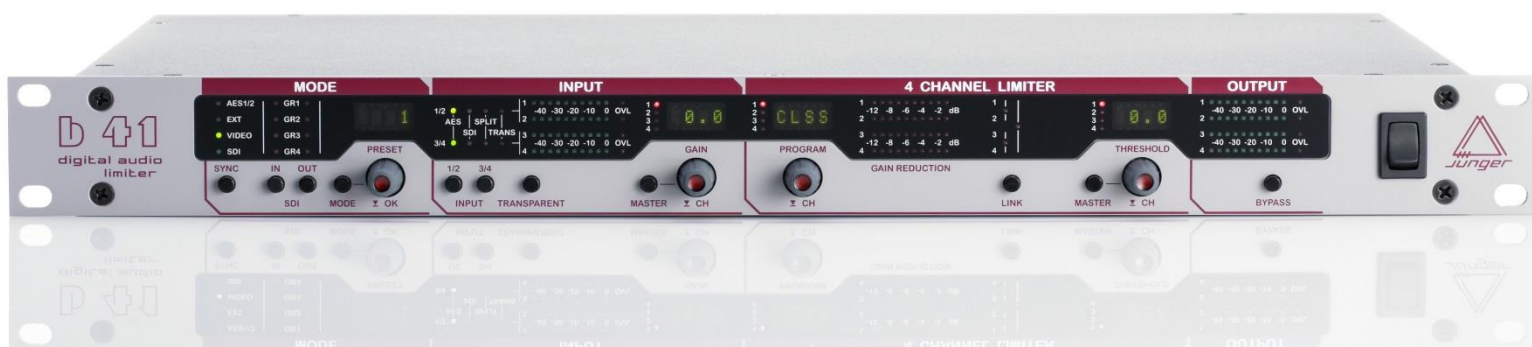

FOREWORD

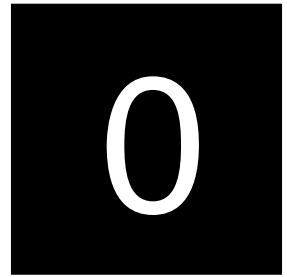

Thank you for buying and for using the 4-channel Digital Audio Limiter b41.

Not only you have acquired the latest generation of digital dynamic range processing, but also a piece of equipment which is unique in its design and specification.

Please read this manual carefully to ensure you have all the information you need to use the 4-channel Digital Audio Limiter b41.

The unit was manufactured to the highest industrial standards and went through extensive quality control checks before it was supplied.

If you have any comments or questions about installing, setting-up or using the b41, please do not hesitate to contact us.

1

CONTENTS

2. Function description	2-1
2.1 Basic description	2-1
2.2 Block diagram	2-2
2.3 Audio signal processing	2-3
2.3.1 Gain	2-3
2.3.2 Limiter Threshold.....	2-3
2.3.3 Limiter Program.....	2-3
2.3.4 Influence of the signal delay time	2-3
2.3.5 Transparent mode	2-3
2.4 Remote system	2-3
	2-4
3. Installation	3-1
3.1 Unpack the unit	3-1
3.2 Power supply	3-1
3.3 Connections	3-1
3.4 Rack mounting	3-1
3.5 Operation safety	3-1
3.6 Synchronization of digital output	3-2
3.7 Remote Control	3-3
3.7.1. GPI Remote Control	3-3
3.7.2. Tally Out	3-4
3.7.3. Serial Remote Control	3-5
4. Location of parts and controls	4-1
4.1 Front panel	4-1
4.2 Rear panel	4-3
4.3 Switches and jumpers for configuration	4-4
4.4 Selection of SDI Split Mode	4-5
4.5 Selection of SDI audio group	4-5

5. Operation	5-1
5.0 Description of setup operation	5-1
5.1 Mode	5-2
5.2 Recalling, saving and editing of presets	5-2
5.3 Input selection	5-4
5.4 Transparent mode	5-4
5.5 Program	5-4
5.6 Link	5-4
5.7 Threshold	5-5
5.8 Bypass	5-5
6. Boot display and trouble shooting	6-1
6.1 Boot display	6-1
6.2 Error messages and trouble shooting	6-1
6.3 Initialization the unit	6-2
7. Application notes	7-1
7.1 B40 series with SDI interface	7-1
7.2 Basic working modes with SDI	7-1
7.3 Remote control with brc	7-3
8. Technical specifications	8-1
9. Warranty and service information	9-1

FUNCTION DESCRIPTION

2

The digital dynamics processor b41 is a professional studio device that processes the dynamic range of digital audio signals.

The dynamic range processor principles developed by Jünger Audio enables the limiter to work with exceptionally high audio quality, without coloration, pumping, breathing, distortion or modulation effects sometimes associated with this type of processor.

In short almost inaudible processing - with ease of use. The outstanding quality of the processing is based on the Multi-Loop dynamic range control principle developed by Jünger Audio.

The unit is easy to operate and requires only a limited number of settings to be made by the user to achieve optimum results. All other parameters necessary for inaudible processing are continuously automatically controlled in response to changes in the programme signal.

features

- 4-channel digital audio limiter
- various link modes: 4-ch, stereo 1/2 or 3/4, ch1...4 independent
- adjustable input gain (channel independent) -15...+15 dB
- adaptive controlled dynamic range processing
limiter on/off, THRS 0...-20 dBFS, PROgram 1..4
- user friendly preset and recall function (10 presets)
- pairwise bit transparent mode input to output
- extern sync mode, AES/EBU or VIDEO (or SDI if optional SDI-interface is present)
- RS-422 interface for serial remote
- GPI interface for parallel remote control, tally output

2.1 BASIC DESCRIPTION

2. FUNCTION DESCRIPTION

2.2 BLOCK DIAGRAM

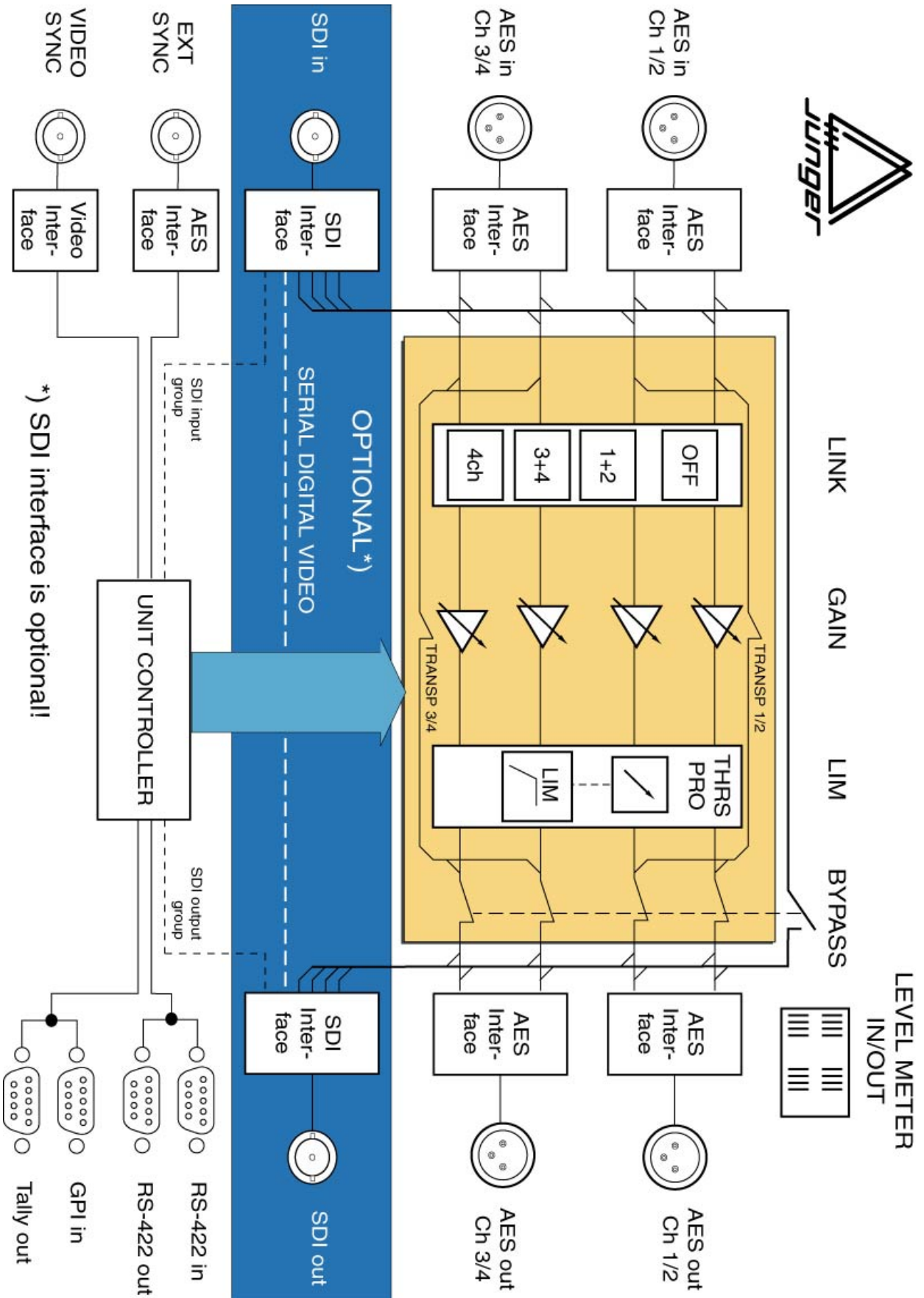

All signal processing is done in the digital domain by Texas Instruments floating point signal processors. The use of 32 bit word length for calculation ensures that there is no deterioration in signal quality, even if an audio signal with a maximum word length of 24 bit is input into the processing of the unit.

GAIN means linear amplification of input or output signals. The input or output gain can be changed in steps of 0.1 dB , within a range from -15...+15 dB.

Adjustment of GAIN is channel independent.

The static characteristics of the b41 usually refers to a digital output level of 0 dBFS (dB Full Scale). This is useful for most applications of the dynamics processor as the on-following digital recording system is supposed to be balanced down to the final bit.

For applications using headroom the output level of can be adjusted within **0 ... -20 dBFS** in steps of 0.1 dB. The limiter threshold determines the maximum output level.

It is possible to choose one of four different **programs** for the dynamics processor. Each provides ideal dynamics control for a different kind of program signal as follows:

- 1 - universal
- 2 - classic
- 3 - pop music
- 4 - speech

Selecting a particular program sets up the optimum parameters of the Limiter (attack and release times, threshold levels and interactions between the multiple signal dependent control circuits) for a particular kind of program material.

The time constants related to the transient response of the control circuit are important for distortionfree processing. They are always adaptively controlled. The algorithm has to guarantee best reaction for fast increasing level of transient signals anytime even if classical music with slow dying out characteristic is processed. In all cases the attack time of the limiter for very short transients is zero.

The release time of the control circuit has influence to the increase of loudness.

The selection of the parameter **PROGRAM** changes the range of time constant values as follows:

PRO	processing time	corresponds to program
-----	5 ms to 0.5 sec	LIVE
	15 ms to 1.2 sec	SPEECH
	30 ms to 2.5 sec	POP
	70 ms to 5.0 sec	UNIVERSAL
	50 ms to 8.0 sec	CLASSIC

**2.3
AUDIO SIGNAL
PROCESSING**

**2.3.1
GAIN**

**2.3.2
LIMITER
Theshold**

**2.3.3
PROGRAM**

2. FUNCTION DESCRIPTION

2.3.3. INFLUENCE OF SIGNAL DELAY TIME

The audio signal delay through the dynamics processor is approx. 2ms due to delaying of the audio signal using internal memory. A small delay is deliberately introduced to the audio signal in order to allow limiter and compressor algorithms which can 'preview' the audio signal before changing it. That is the signal curve can be changed before maximum level is reached. This delay must be considered before attempting to mix signals processed by the dynamics processor with other undelayed signals.

When mixing together a delayed signal and a direct signal there may be cancellation of the signal waveform at some frequencies and reinforcement of the waveform at other frequencies (comb filter effect). Corresponding 2ms delay of direct signals should therefore be carried out before mixing them with delayed processed signals.

2.3.4 TRANSPARENT MODE

In case that the input signal (audio pair 1/2 or/and 3/4) is not audio (but AC-3, Dolby E, MPEG..) the input can be feeded directly to the related output bit transparent (no bit changes). The unit is switching to *transparent* automatically if "non audio" flag in the Channel Status Bit of the AES signal is set. Otherwise transparent mode can be set manually by the user.

2.4 REMOTE SYSTEM

The digital audio limiter b41 is fitted with an serial remote interface in RS-422 format.

Every device needs a device address to be registered in a remote system. The address can be selected with the ADDR switch on the rear panel. 16 addresses are selectable (0..F). The changed address is valid with next power-on reset.

Up to 16 limiter b41 can be controlled from one remote panel.

Device model name and device address are to recognize using the remote protocol of serial remote interface by an automation system or by PC. With it various boxes can be combined in one remote system or remote chain. However a maximum of 16 devices per model can be controlled in one chain.

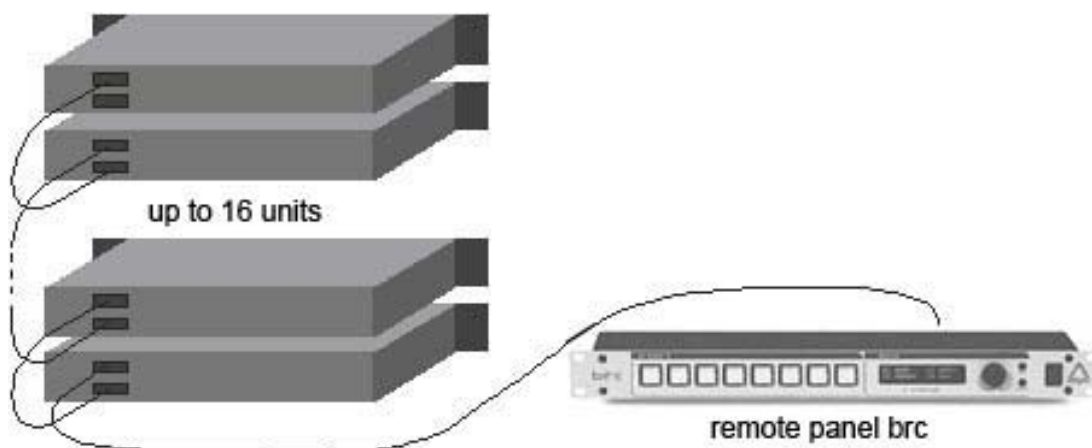

INSTALLATION

3

The digital audio limiter b41 was carefully packed in the factory and the packaging was designed to protect the equipment from rough handling. Please examine carefully the packaging and its contents for any signs of physical damage, which may have occurred in transit.

The digital audio limiter b41 is a device under the safety category *Schutzklasse 1* in keeping with the VDE 0804 standards and may only be used with power supply installations built according to regulations.

Check the voltage details printed at the rear panel are the same as your local mains electricity supply.

The digital audio limiter b41 is equipped with standard connectors (see also chapter 3).

Before connecting the digital audio limiter b41 switch the power off at all connected units.

The digital audio limiter b41 is made as standard 19" unit (EIA format). It occupies 1 RU (44 mm height) space in a rack. Please allow at least additional 3" depth for the connectors on the rear panel.

When installing the unit in a 19" rack the rear side of the unit needs some support, especially for mounting in flight cases.

The digital audio limiter b41 should not be installed near units which produce strong magnetic fields or extreme heat. Do not install the filter processor directly above or below power amplifiers.

If, during operation, the sound is interrupted or displays no longer illuminate, or if abnormal odor or smoke is detected immediately disconnect the power cord plug and contact your dealer or Jünger Audio.

3.1 UNPACK THE UNIT

3.2 POWER SUPPLY

3.3 CONNECTIONS

3.4 RACK MOUNTING

3.5 OPERATION SAFETY

3. INSTALLATION

3.6 SYNCHRONIZATION OF DIGITAL OUTPUT

The digital audio limiter b41 has a digital signal output only. To the problem-free combination of following digital devices, the digital signal processing can be locked to an external clock reference. The selection of the corresponding input is made in the SYNC MODE menu. If the chosen sync input is connected with the sync signal, this signal is used for synchronization automatically. The digital output signal can be clocked with the following clock frequencies:

CH 1/2 locks with the clock frequency of the input signal at digital input CH 1/2 (AES/EBU, 48 kHz)

EXT SYNC locks with the clock frequency at the external sync input (AES/EBU, 48 kHz)

VIDEO locks with the clock at the Video sync input (internal 48 kHz)

SDI VIDEO locks with the clock at the SDI input (internal 48 kHz)

Both digital outputs CH 1/2 and CH 3/4 are locked with same clock frequency.

Note: SDI sync is available only if SDI interface is installed!

**3.7
REMOTE
CONTROL**

**3.7.1
GPI REMOTE
CONTROL
(PARALLEL
REMOTE)**

The digital audio limiter b41 can be remote-controlled by means of parallel GPI contacts.

use: remote-controlled changeover of presets

connector: D-SUB 15pin, female

Pin assignments

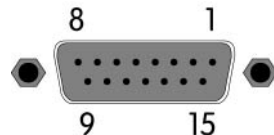

Pin	Signal name	Logic	I/O	Functions
1	PRESET1	L	I	recall preset1
2	PRESET2	L	I	recall preset2
3	PRESET3	L	I	recall preset3
4	PRESET4	L	I	recall preset4
5	PRESET5	L	I	recall preset5
6	PRESET6	L	I	recall preset6
7	PRESET7	L	I	recall preset7
8	PRESET8	L	I	recall preset8
9	MUTE	L	I	Muting outputs
10	BYPASS	L	I	bypass on
11	not used			
12	Phase rev ch1/2	L	I	
13	Phase rev ch3/4	L	I	
14	Common pin			External voltage feed
15	+5V		O	Test power source

Ground on shield of the connector only!

Electrical specification:

GPI input potential free by opto-coupler, **low active**
 OFF: +3.5...+30V between GPI input and pin14
 ON: less then 1.5V

Note: If using an external voltage feed it has to be connected to pin 14!
 External Ground is switching the GPI on any of the inputs.
 An internal voltage feed is available on pin 15. Ground is available from the shield of the connector only! By using the internal voltage feed (connect PIN 14+15) there is no electrical isolation given anymore.

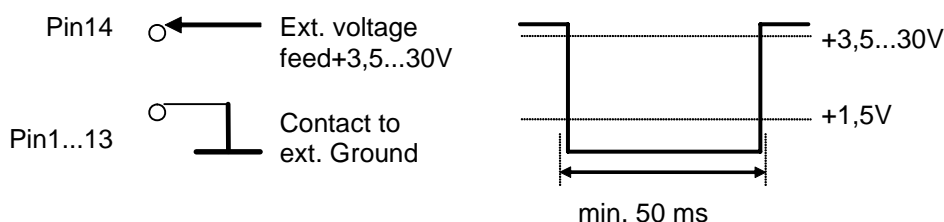

3. INSTALLATION

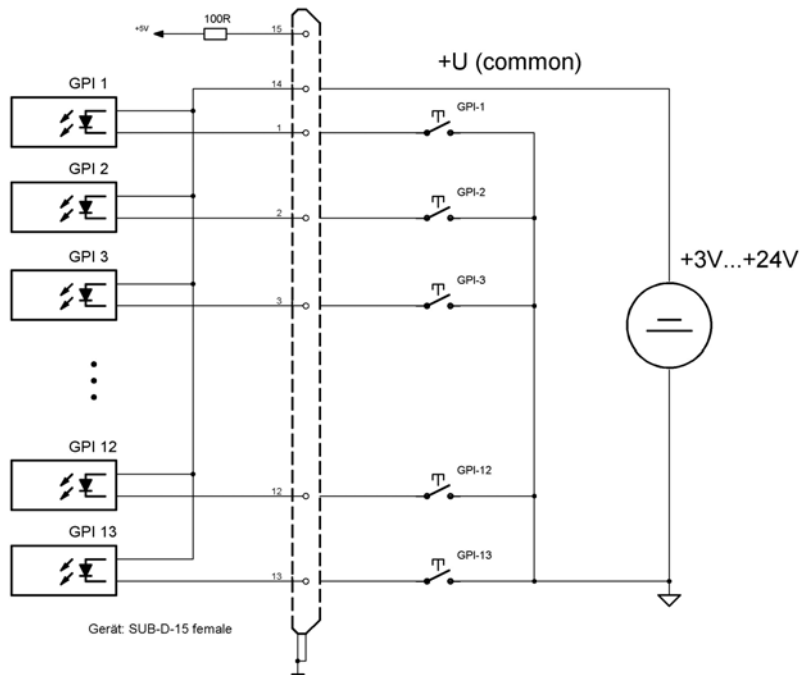

3.7.2 TALLY OUT

The digital audio limiter b41 can transmit specific device statuses via parallel Tally lines.

use: Control of the remote-controlled changeover of presets

connector: D-SUB 15pin, male

Pin assignments

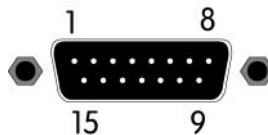

Pin	Signal name	I/O	Functions
1	T1 open contact	O	preset1 recalled
2	T2 open contact	O	preset2 recalled
3	T3 open contact	O	preset3 recalled
4	T4 open contact	O	preset4 recalled
5	T5 open contact	O	preset4 recalled
6	T6 open contact	O	preset4 recalled
7	T7 open contact	O	preset4 recalled
8	T8 open contact	O	preset4 recalled
9	T9 open contact	O	mute
10	T10 open contact	O	bypass
11	T11 open contact	O	Not used
12	T12 open contact	O	Not used
13	T13 open contact	O	Not used
14	T14 open contact	O	Not used
15	root		Common root contact

Electrical specification:

Tally output type: normally open relais contacts
Contact rating: 1A 24 VDC, 0,5 A 125 VAC
 max. 30 W 62,5 VA
 max. 60 VDC, 125 VAC

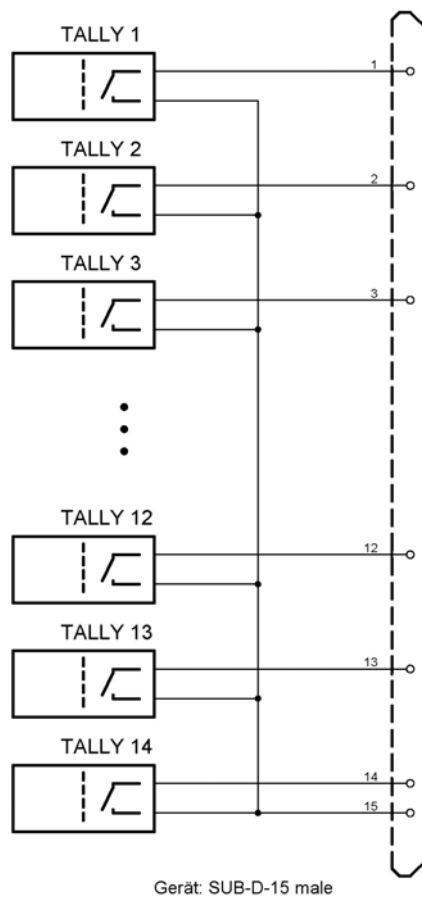
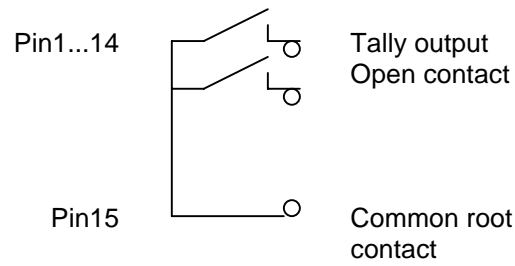

3. INSTALLATION

3.7.3 SERIAL REMOTE CONTROL (RS-422)

The digital audio limiter b41 can be remote-controlled by means of serial remote RS-422.

use: remote-controlled changeover of presets

protocol: available on request

connector: D-SUB 9pin, input - female
output - male

Pin assignments

The cable is wired 1:1 completely, the shield of the cable must be connected on both ends!



Pin	Signal name	Functions
1	DSR + out	Data set ready
2	DSR - out	
3	SENSE in	Interrogation Remote
4	RXD + out	Receive data
5	RXD - out	
6	DTR + in	Data terminal ready
7	DTR - in	
8	TXD + in	Transmit data
9	TXD - in	



Pin	Signal name	Functions
1	DSR + in	Data set ready
2	DSR - in	
3	GND	GND
4	RXD + in	Receive data
5	RXD - in	
6	DTR + out	Data terminal ready
7	DTR - out	
8	TXD + out	Transmit data
9	TXD - out	

Electrical specification:

signal in-/outputs

TTL-level

LOCATION OF PARTS AND CONTROLS



All control elements gives direct access.
In menu modes the alphanumeric display above the related button or rotary knob is showing the specific function.

4.1. FRONT PANEL

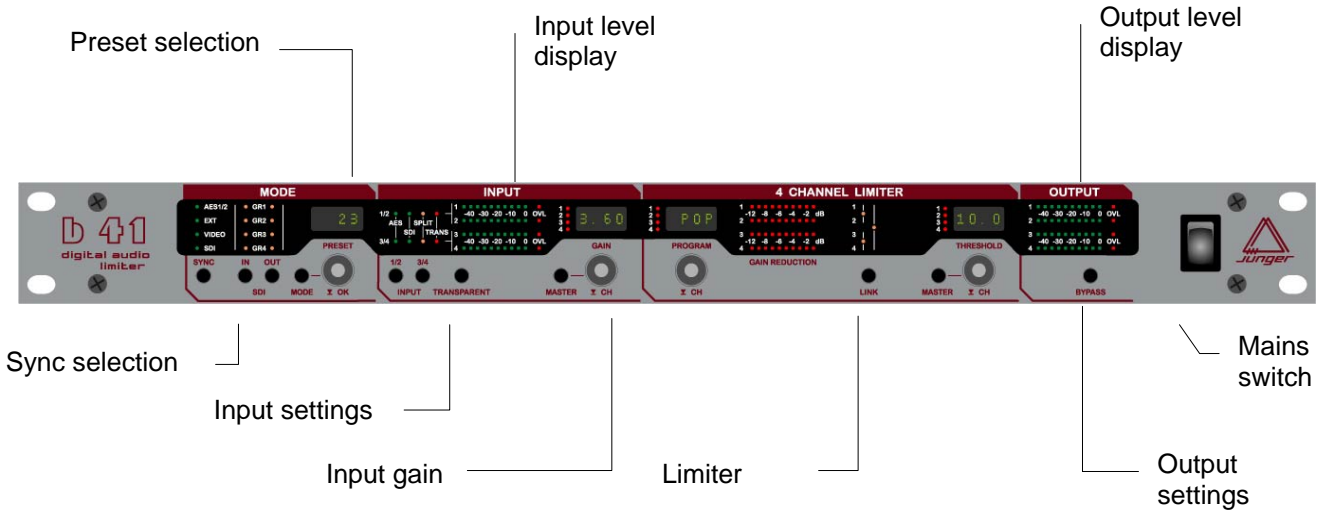

fig. 1: front panel b41

CONTROL ELEMENTS

SYNC	selection of sync input
IN / OUT	group selection for SDI input/output
PREVIEW	offline editing of presets
PRESET	preset selection and administration
1/2 and 3/4	input selection AES / SDI
TRANSPARENT	bit transparent mode for ch1/2 or 3/4

mode

input

4. LOCATION OF PARTS AND CONTROLS

input	MASTER	ganging control knob for ch1...4
	GAIN	selection (push) and adjustment (turn) of output gain
limiter	PROGRAM	selection of limiter characteristic
	LINK	selection of channel link mode
	THRESHOLD	adjustment of limiter threshold
output	BYPASS	switches bypass on and off

4.2. REAR PANEL

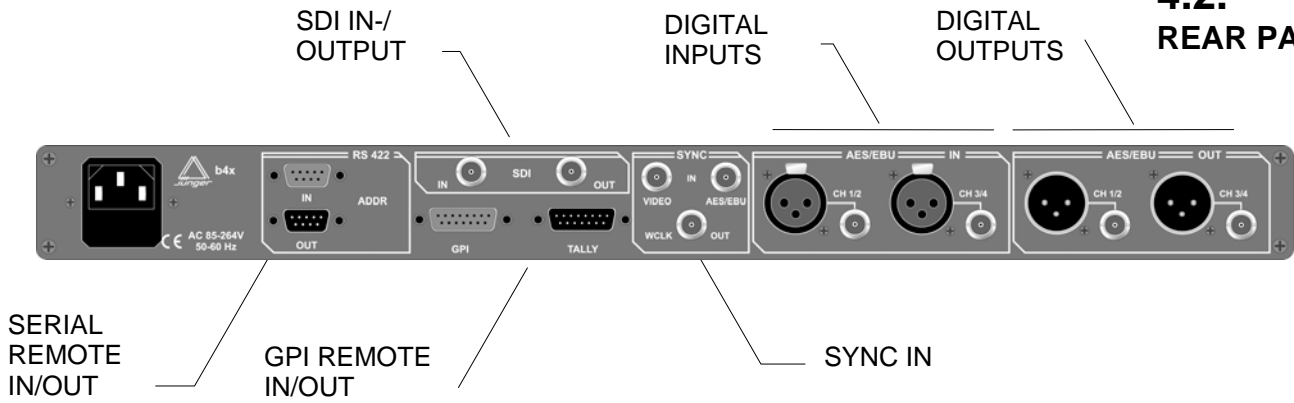

fig. 2: rear panel b41

POWER INPUT

IEC mains input connector 100-240V, 50/60 Hz with integrated fuse

REMOTE

serial remote interface RS-422

connector: 9pin SUB-D, input - female, output - male

GPI

paralle remote interface

TALLY-out open relais contact

connector: 15pin SUB-D, male

GPI-in +3,5...+30V potential-free

connector: 15pin SUB-D, female

SYNC

AES/EBU input for ext. sync signal (AES 3 format, 75 Ohm, unbal)

connector: BNC socket

VIDEO input for video sync signal (blackburst, 75 Ohm, unbal)

connector: BNC socket

W-CLOCK output for wordclock sync signal, TTL level, unbal.

connector: BNC socket

SDI IN / OUT (only if installed!)

Input/output for serial digital video (ITU-R BT.601, SMPTE 272M-A) with embedded audio

Format: 270 Mb/s, 525/625 line rate, 75 Ohm,

connector: BNC socket

DIGITAL IN

input for AES/EBU standard format

connector: XLR female panel jack

1- ground, 2-3 signal, balanced

connector: BNC socket 75 Ohm, unbalanced

DIGITAL OUT

output for AES/EBU standard format

connector: XLR male panel jack

1- ground, 2-3 signal, balanced , 4 Vpp

connector: BNC socket 75 Ohm, unbalanced, 0.5V pp

4. LOCATION OF PARTS AND CONTROLS

4.3 SWITCHES AND JUMPERS FOR CONFIGURATION

Some basic settings are to select by switches on the rear panel or by switches and jumpers at the internal circuit boards of the unit. These settings can occur general changes for operation and should be made by qualified engineering staff only.

Rear panel

Selection of the device address for serial

remote, 16 device addresses selectable

Note: Within a line of remote controlled units every device needs a different address! The selected address is valid after next power-on reset of the unit.

Internal

To set any internal jumper or switches it is necessary to open the unit.

PLEASE DO NOT MAKE ANY ALTERATIONS WITH THE MAINS STILL CONNECTED TO THE UNIT!

Loosen the screws on the top cover and remove. Then you can see all jumper and switches as shown in the drawing below. After setting of jumper or switches reassemble the unit in opposite order.

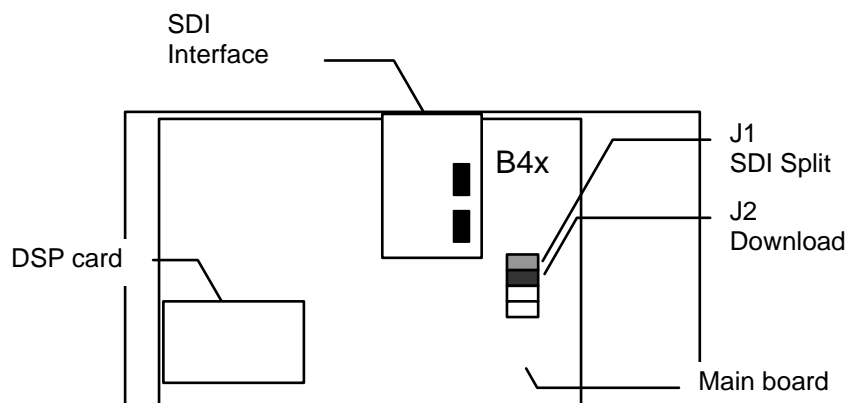

Units with SDI interface can be used in SDI split mode:
 Audio in path SDI input > AES output
 Audio out path SDI output > dsp processing > AES output
 (see also 2.5)

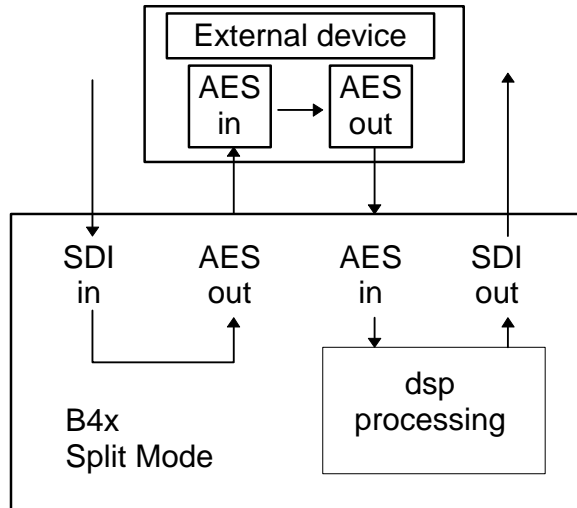

The selection of split mode (SDI DIRECT) is made by setting jumper J1 on main board of the unit.

The 4-channel processors of b40 series fitted with SDI-interface are compatible with the standard SMPTE 272M-AB. They support 48 kHz synchronous audio sampling with 20 bit word length.

The standard allows up to four groups each of four mono audio channels. (Usually used by most of D-VTR's and other equipment is Group 1 with 48 kHz synchronous sampling.)

Group selection and other settings are to configure with switches on the SDI board as described following:

**4.4
SELECTION OF
SDI SPLIT MODE**

**4.5
CONFIGURATION
OF SDI INTERFACE**

OPERATION



The use of the digital audio limiter b41 is very easy.



The setup or the programming of the digital audio toolbox b40 is made by adjustment of various parameters and settings.

The description is made related to the functional blocks on the front panel.

- 5.1 mode
- 5.2 recalling, saving and editing of presets
- 5.3 input selection
- 5.4 transparent mode
- 5.5 program
- 5.6 link
- 5.7 threshold
- 5.8 bypass

5.0 DESCRIPTION OF OPERATIONS

Following syntax is used:

SYMBOL	ACTIVITY
describes how to use button or rotary knob	describes action or function of button or rotary knob
 push	
 turn	
 push + turn	

5. OPERATION



5.1 MODE

Selection of sync signal input

 push	SYNC	selection of sync-signal input
	1/2	unit is synchronized with AES input channel 1/2 (AES 48kHz)
	EXT	unit is synchronized with AES input signal at external sync input
	VIDEO	unit is locked to video signal at video input (with 48kHz)
	SDI	unit is locked to SDI signal at SDI input (with 48kHz)

Note: SDI sync is available only if SDI input is active! If SDI sync is selected only the SDI input LED lits. All LED's in sync display are switched off!





Selection of group of audio for SDI signal

 push	IN	SDI audio group selection for deembedder
		and independent to that
 push	OUT	SDI audio group selection for embedder

5.2 RECALLING, SAVING AND EDITING OF PRESETS





All adjusted parameters of TRANSP, DELAY, INPUT GAIN, MATRIX, OUTPUT GAIN and FADE can be stored into presets.

Recall of presets

 push	PREVIEW	until LOAD appears in the window.
 push	PRESET	to enter preset load mode, "L" and a blinking number 1..8 are to see
 turn	PRESET	to select the requested preset 1....8
 push	PRESET	to load selected preset. The preset number appears in the window.
	or	
 push	PREVIEW	to exit without loading.







As soon as one of the in the preset stored parameter is changed by manually operation a star symbol appears beside the number in the window to show that the previously loaded preset is not more present.

Storage of presets

	PREVIEW	until SAVE appears in the window.
push		
	PRESET	to enter preset save mode, "S" and a blinking number 1..8 are to see
push		
	PRESET	to select the preset 1....8 to save
turn		
	PRESET	to save selected preset. The preset number appears in the window.
push		
	or	
	PREVIEW	to exit without saving.
push		

Note: All former stored preset values are overwritten at the moment of new storage into this preset! Just as after initialization of the unit all presets are overwritten with factory presets.

Editing of presets (PREVIEW mode, viewing and changing preset content off-line without influencing running audio)

	PREVIEW	until EDIT appears in the window.
push		
	PRESET	to enter preset edit mode, "E" and a blinking number 1..8 are to see
push		
	PRESET	to select the preset 1....8 to edit
turn		
	PRESET	to enter selected preset in edit mode
push		
	PRESET	to save back selected preset. The running preset number appears in the window.
push		
	or	
	PREVIEW	to exit without saving.
push		

Note: All former stored preset values are overwritten at the moment of new storage into this preset! Just as after initialization of the unit all presets are overwritten with factory presets.

5. OPERATION

5.3 INPUT SELECTION



1/2 or 3/4

to switch for the input 1/2 or 3/4 between AES and SDI

5.4 TRANSPARENT MODE



TRANSPARENT

to establish bit transparent connection between input and output 1/2 or 3/4 or 1/2 and 3/4 (necessary to pass non-audio bit streams through without changing)

5.5 PROGRAM

It is possible to choose one of different **programs** for the dynamics processor. Each provides ideal dynamics control for a different kind of programme signal as follows:

live, speech, pop music, universal, classic

Selecting a particular program sets up the optimum parameters of the dynamics processor (attack and release times, threshold levels and interactions between the multiple signal dependent control circuits) for a particular kind of programme material.

Generally speaking, release times are longest when using the classical setting and shortest when using the speech setting.

(In order to understand the basic Multi-loop principle of the Jünger Audio dynamics processors please refer to chapter 6.1).



PROGRAM

selection of channel

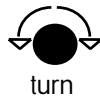

PROGRAM

setting the program for the selected channel

5.6 LINK

Coherent audio signals can be linked. The limiter reduction is done for all linked channels with the same value determined by the channel with highest audio level. Stereophonic and surround information or even the panning between channels will not be changed for linked channels.

Following links are possible:

CH1 + CH2 + CH3 + CH4	(all 4 channels linked)
CH1 + CH2 CH3 + CH4	(two pairs linked)
CH1 + CH2 CH3 CH4	(one pair linked)
CH1 CH2 CH3 + CH4	(one pair linked)
CH1 CH2 CH3 CH4	(all channels solo)





LINK

selection of link mode

Limiter threshold level means maximum output level. The output level will never be more than limiter threshold level. The limiter threshold level can be changed in steps of 0.1 dB , within a range from -20...0 dBFS.

Adjustment of limiter threshold is channel independent if the channels are not linked. Otherwise there is one threshold level only for all linked channel.

- 
push **PROGRAM** selection of channel
- 
turn **PROGRAM** setting the program for the selected channel
- 
push **MASTER** to adjust all channels together with the same value

BYPASS is bypassing the signal processing of the unit.
BYPASS is working for all configurations.

- 
push **BYPASS** switching bypass on or off

display: BYP. in the window

5.7 THRESHOLD

5.8 BYPASS

BOOT DISPLAY AND TROUBLE SHOOTING

6

display	meaning / explanation
LIMITER	display of processor model
B41	display of type
ADR. x	display of unit address for serial remote control

display	error / message	remedies
NO SYNC	no sync at sync input!	<ul style="list-style-type: none"> ■ connect the sync input (selectable in SYNC field) with valid input signal <ul style="list-style-type: none"> ➤ CH 1/2: sync on DIGITAL IN CH 1/2 ➤ EXT: sync on SYNC AES/EBU ➤ VIDEO: sync on SYNC VIDEO ➤ SDI: sync on SDI input
NO SDI!	SDI input selected, no valid SDI signal received!	<ul style="list-style-type: none"> ■ check the availability of SDI data stream or ■ select another input

6.1 BOOT DISPLAY

6.2 ERROR MESSAGES AND TROUBLE SHOOTING

6.3 INITIALIZATION THE UNIT

Should have remained the device no more operable and/or in the program execution stand, recommends itself an initialization the device.

During initialization, all storage areas important for the program and registers are loaded with the factory setup and the program is restarted.

Any button is to be held pressed in order to initialize the device during switch-on of the device until the program started. To the start of the program and at the completion of the displays (how described in 6.1), the device is ready for operation with the factory setup.

After an initialization of the device, all user presets and adjustments are erased and/or overwritten by the factory setup!

APPLICATION NOTES

In digital video recording technology four digital audio channels are the standard configuration. This channel capacity is used increasingly in production and post-production for surround sound, providing mix options and for multi-lingual productions.

Quite often it is necessary to make corrections or changes to the audio which until now required the use of an expensive digital audio mixer. These tasks can now be easily solved with the Jünger Audio range of digital audio toolboxes. Simple processing for up to four digital audio signals may be carried out quickly and efficiently.

Using the SDI versions (SDI=Serial Digital Interface, digital component video format with 270Mb/s transmission) b40 series can process embedded audio.

The standard allows up to four groups each of four mono audio channels. Usually used by most of D-VTR's and other equipment is Group 1 with 48 kHz synchronous sampling. Synchronous means that the audio clock is genlocked to the associated video. Each channel can have up to 20 bits of resolution per audio sample.

The 4-channel processors of b40 series fitted with SDI-interface are compatible with the standard SMPTE 272M-AB. They support 48 kHz synchronous audio sampling with 20 bit word length.

The Jünger Audio SDI interface provides for one group of four audio channels to be extracted from or inserted into the SDI data stream. To address a specific channel group the group selection is possible (see 4).

The b40 provides an optional SD- or HD-SDI board. When you switch on the device the plugged in interface will be indicated in the display

FEATURES

- Bypass relay for SDI IN >SDI OUT
- Bit transparent for coded data streams (e.g. DOLBYE/20bit)
- De-embedder: user selectable de-embedding of one group
- Embedder: user selectable embedding to one of 4 groups
- SDI-SYNC: SDI input can be the clock source of the device
- For HD-SDI: Multi-Format HD/SD operation with auto detection

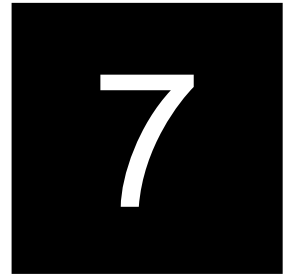

7.1 B40 SERIES WITH SDI-INTERFACE

7. APPLICATION NOTES

7.2 BASIC WORKING MODES WITH SDI

For the basic working mode the input of the digital audio processing can be selected between AES/EBU or SDI (serial digital video with embedded audio). The processed signals are present at both outputs always - at AES/EBU and SDI.

There are two additional working modes using the SDI interface. SDI Bypass is bypassing the SDI data stream. In this case only extracted audio is processed and available at AES output. In Split Mode the audio path is splitted. Embedded audio can be processed with external equipment via AES interface.

Following illustration shows working modes:

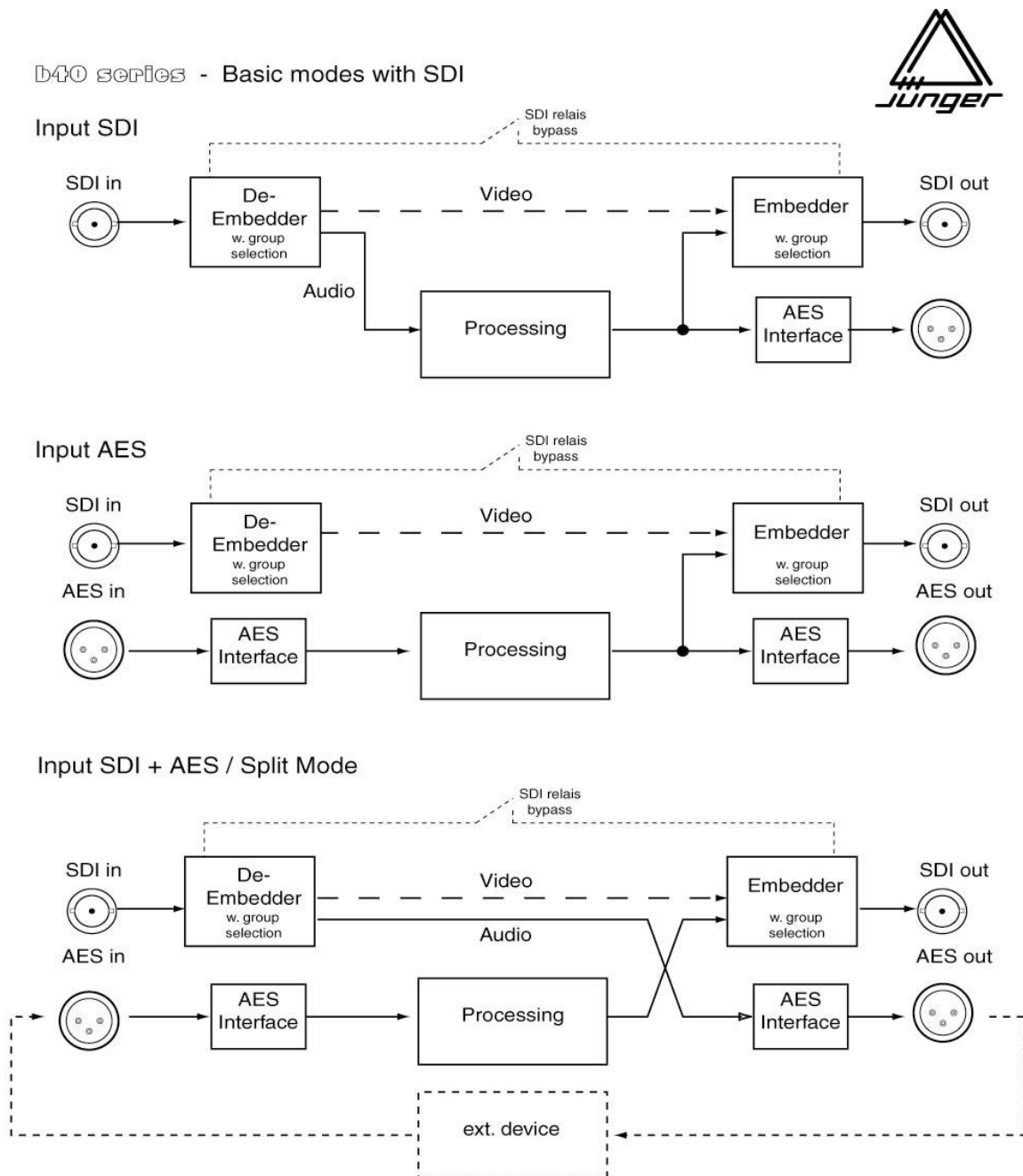

The Digital Audio Limiter b41 can be used remote controlled by the programmable remote control panel brc.

**7.3
REMOTE CONTROL
WITH BRC**

Fig . 8.1: programmable remote control brc

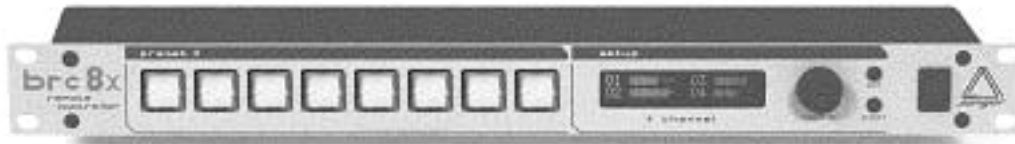

All settings of the b41 toolbox can be made on the front panel of the box or via the edit menus of brc remote control. Working with the brc remote control panel means rapid changes of preprogrammed presets by pushing one button only.

Fig . 8.2: installation with remote control brc

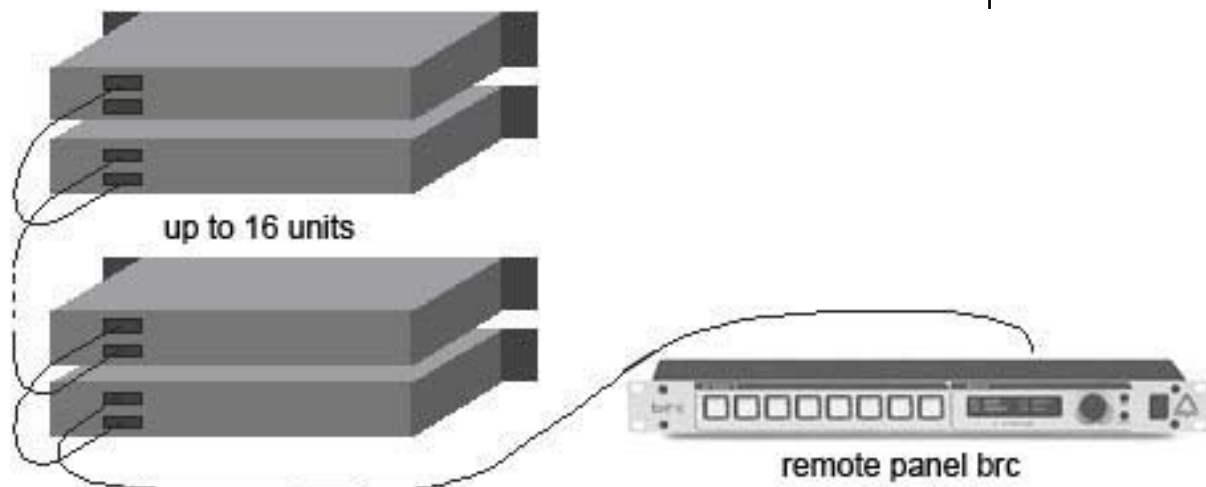

features of brc:

- universal remote control panel (RS-422)
- remote operation of several units (up to 16 devices from B40 series 2nd generation)
- remote panel is detecting connected units
- remote control panel brc8x as programmable control unit with "one touch" access of presets by hot keys
- 19" case, 1RU, only 75 mm depth!

TECHNICAL SPECIFICATIONS

sample rate : 48 kHz
 audio data format : 24 bit (AES/EBU), 20 bit (SDI)

DIGITAL IN/OUT

AES/EBU

connector : XLR, 110 Ohm, balanced
 BNC, 75 Ohm, coaxial
 input format : AES professional, AES consumer
 output format : same as input format

SDI (only for SDI version)

connector : BNC, 75 Ohm, coaxial
 data rate : 270 Mb/s, 525/625 Line rate
 format : serial digital component video 4:2:2
 with embedded audio
 (ITU-R BT.601, SMPTE 272M-A)
 level: 800 mV +/- 10%
 equalisation : appr. 180 m (Belden 8281)
 audio data: 4 channels, 20 bit
 features : SDI relais bypass
 independent group selection for
 de-embedder and embedder

SDI (only for SDI version)

SD-SDI

VIDEO :

standard:	SMPTE 272 M-A,	270 Mbit	SD-SDI
connection:	BNC, 75 Ohm, coaxial		
signal level:	800mV ±10%		
equalisation:	300m (Belden 8281 , 270 MHz)		
return loss:	>15 dB		

supported video standards:

SD 525/59.94	SMPTE 125M
SD 625/50	SMPTE 125M



**digital signal
processing**

**digital
in- / outputs**

**SDI
in- / output**

8. TECHNICAL SPECIFICATIONS

AUDIO :
audio data format : 20 Bit, transparent for C-Bit and U-Bit according to AES3
audio sample rate : 48 kHz synchronous to video-carrier
latency : (deembedder + embedder)
SD : < 2,6 msec

GENERAL :
power supply : +5V DC
consumption : approx. 500 mA
dimension : 3RU, 4HP, 160mm depth (EUROPA size pcb)
temperature : 10°C to 40°C
humidity : 90%, non condensing

HD-SDI

technical specifications

VIDEO :

standard:	SMPTE 299M	1,485 Gbit	HD-SDI
	SMPTE 272M–A, C	270 Mbit	SD-SDI
connection:	BNC, 75 Ohm, coaxial		
signal level:	800mV ±10%		
equalisation:	130m (Belden 1694A, 1.485GHz)		
	300m (Belden 8281 , 270 MHz)		
return loss:	>15 dB (1.485 GHz)		

supported video standards:

HD 720/60	SMPTE 296M	HD 1080/25	SMPTE 274M
HD 720/50	SMPTE 296M	HD 1080/24	SMPTE 274M
HD 720/30	SMPTE 296M	HD 1080/50	SMPTE 295M
HD 720/25	SMPTE 296M	HD 1035/60	SMPTE 260M
HD 720/24	SMPTE 296M		
HD 1080/60	SMPTE 274M	SD 525/59.94	SMPTE 125M
HD 1080/50	SMPTE 274M	SD 625/50	SMPTE 125M
HD 1080/30	SMPTE 274M		

all HD-standards are supported also with their 1/1001-frame-rates

AUDIO :
audio data format : 24 Bit, transparent for C-Bit and U-Bit according to AES3
audio sample rate : 48 kHz synchronous to video-carrier (SD and HD)
32 kHz ... 48 kHz asynchronous to video-carrier (HD only)
latency : (deembedder + embedder)
HD : < 800µsec
SD : < 2,6 msec

GENERAL :
power supply : +5V DC
consumption : approx. 1.000 mA
dimension : 3RU, 4HP, 160mm depth (EUROPA size pcb)
temperature : 10°C to 40°C
humidity: 90%, non condensing

SYNC IN

AES/EBU

connector : BNC, 75 Ohm, coaxial

level : 0,5 ... 5 Vpp

input format : AES professional, AES consumer

VIDEO

connector : BNC, 75 Ohm, coaxial

level : 0...1 Vpp

input format : Blackburst or PAL/NTSC composite video

sync

in- / outputs

REMOTE

serial remote interface RS-422 in/out

level : TTL

connector : 9 pin SUB-D male/female

GPI parallel remote

level : +3...+30V, H-active, optocoupler

connector : 15 pin SUB-D female

Tally Out

level : normally closed relais contacts

Contact rating: 1A 24 VDC, 0,5 A 125 VAC

max. 30 W 62,5 VA

max. 60 VDC, 125 VAC

connector : 15 pin SUB-D male

remote control

GENERAL

power consumption : appr. 15 VA

dimensions : 19", 1 RU, 250 mm depth

weight : appr. 5 kg

optional : programmable remote control brc

9

WARRANTY AND SERVICE INFORMATION

JÜNGER AUDIO grants a two-year warranty on the

4-channel digital audio limiter b41

If the unit has to be serviced, please send it
ideally in the original box, to:

JÜNGER AUDIO - Studioteknik GmbH

Justus-von-Liebig-Str. 7

D - 12489 Berlin
GERMANY

Tel.: (*49) -30-677721-0
Fax.: (*49) -30-677721-46



KONFORMITÄTSERKLÄRUNG

DECLARATION OF CONFORMITY

Geräteart : **4ch digital toolbox**
Type of equipment : **4ch digital toolbox**

Produkt / Product : **b41**

Das bezeichnete Produkt stimmt mit den Vorschriften folgender EU-Richtlinie(n) überein:
The aforementioned product complies with the following European Council Directive(s):

89/336/EWG (geändert durch 91/263/EWG und 92/31/EWG)
(changed by 91/263/EEC and 92/31/EEC)
Richtlinie der Rates zur Angleichung der Rechtsvorschriften der Mitgliedsstaaten über die elektromagnetische Verträglichkeit
Council Directive on the approximation of the laws of the Member States relating to electromagnetic compatibility

73/23/EWG (geändert durch 93/68/EWG)
(changed by 93/68/EEC)
Richtlinie des Rates vom 19. Februar 1973 betreffend elektrische Betriebsmittel zur Verwendung innerhalb bestimmter Spannungsgrenzen
Council Directive of February 19th 1973 concerning electrical equipment for operation within certain voltage limits

Zur vollständigen Einhaltung dieser Richtlinie(n) wurden folgende Normen herangezogen:
To fully comply with this(these) Directive(s), the following standards have been used:

EN 55022 : 1987
EN 50082-1 : 1993
EN 60065 : 2002

Dieser Erklärung liegen zugrunde : Prüfbericht(e) des EMV-Prüflabors
Interne Vorschriften zur Sicherheits-Prüfung
This certification is based on : Test report(s) generated by EMC-test laboratory
Internal regulations for safety check

MEB Messelektronik Berlin : Kalibrier- und Prüflabor
accredited EMC laboratory

Aussteller / Holder of certificate : Jünger Audio Studioteknik GmbH
Justus-von-Liebig-Strasse 7
D - 12489 Berlin

Berlin, 18.03.2003
(Ort/Place) (Datum/Date) (Herbert Jünger, Geschäftsführer/Managing Director)

b41



Jünger Audio GmbH
Justus-von-Liebig-Straße 7
12489 Berlin
Germany



phone: +49 30 6777 21 0
fax: +49 30 6777 21 46
info@jungeraudio.com
www.jungeraudio.com